

TITAN VI CARBON

Timer Backwash Filtration System

Installation and Operation Manual



Backwash Carbon Filter

Manufacturer's Warranty

To the original purchaser, the valve body, mineral container carry an unconditional non-prorated 10-year guarantee, replaced F.O.B. Orem, Utah

The water filter manufactured by **Holts Water Conditioning** is unconditionally guaranteed against defects in workmanship and materials for a period of **1 year** from the date of original purchase at the original installation site with city potable water supply.

Should any part except those listed above prove defective after the initial one-year period from the original date of purchase, said part will be repaired, rebuilt, or replaced at the manufacture's option for a maximum charge of \$65.00 F.O.B Orem, Utah, provided the part is returned to the manufactures place of business, with transportation and other charges incurred in replacement or repair of defective parts paid by customer.

Holts Water Conditioning will not be held responsible/liable for Freight/Shipping charges, labor/service charges, loss(property or other), or damages caused by a defective part.

The following items will Void this manufacturer's warranty:

- All systems must have main feed water pressure greater than 20 P.S.I. but lower than 90 P.S.I
- All systems must have water temperature over 34 degrees Fahrenheit and under 90 degrees Fahrenheit. Any vacuum causing reverse flow allowing Hot water to enter any system will Void the Manufacturer's warranty.
- Water entering all systems must be absent any sediment of any type (Not limited to, Sand, Silt, Turbidity), causing Organic loading
- Water must have Iron levels below .25ppm. Warranty does not cover Iron fouling
- If any system has been subject to misuse, neglect, alterations, Brown outs, power surges, Direct UV sunlight, misapplication, installation error and/or accident caused by fire, flood, earthquake, or any other natural disaster.
- Warranty does not cover systems that have been installed on a water supply of unknown water quality or Microbiologically unsafe.



369 South Mountainway Drive Orem, UT 84058
(801) 426-9243

General Warnings

1. The control valve, fittings and/or bypass are designed to accommodate minor plumbing misalignments but are not designed to support the weight of a system or the plumbing.
2. Do not use Vaseline, oils, other hydrocarbon lubricants or spray silicone anywhere. A silicon lubricant may be used on black o-rings but is not necessary. **Avoid any type of lubricants, including silicone, on red or clear lip seals.**
3. The nuts and caps are designed to be unscrewed or tightened by hand or with the special plastic wrench. If necessary pliers can be used to unscrew the nut or cap. Do not use a pipe wrench to tighten or loosen nuts or caps. Do not place screwdriver in slots on caps and/or tap with a hammer.
4. Do not use pipe dope or other sealants on threads. Teflon tape must be used on the threads of the 1" NPT elbow or the 1/4" NPT connection and on the threads for the drain line connection. Teflon tape is not necessary on the nut connection or caps because of O-ring seals.
5. After completing any valve maintenance involving the drive assembly or the drive cap assembly and pistons, unplug power source jack from the printed circuit board (black wire) and plug back in. This resets the electronics and establishes the service piston position. The display should flash all wording, then flash the software version (e.g. 154) and then reset the valve to the service position.
6. All plumbing should be done in accordance with local plumbing codes. The pipe size for the drain line should be a minimum of 1/2". Backwash flow rates in excess of 7 gpm or length in excess of 20' require 3/4" drain line.
7. Solder joints near the drain must be done prior to connecting the drain line flow control fitting. Leave at least 6" between the drain line control fitting and solder joints when soldering pipes that are connected on the drain line control fitting. Failure to do this could cause interior damage to the drain line flow control fitting.
8. When assembling the installation fitting package (inlet and outlet), connect the fitting to the plumbing system first and then attach the nut, split ring and O-ring. Heat from soldering or solvent cements may damage the nut, split ring or O-ring. Solder joints should be cool and solvent cements should be set before installing the nut, split ring and O-ring. Avoid getting primer and solvent cement on any part of the o-rings, split rings, bypass valve or control valve.
9. Plug into an electrical outlet. Note: All electrical connections must be connected according to local codes. (Be certain the outlet is uninterrupted.)
10. Install grounding strap on metal pipes.

Table 1
System Specifications

Minimum/Maximum Operating Pressures	20 psi (138 kPa) - 90 psi (621 kPa)
Minimum/Maximum Operating Temperatures	40°F (4°C) – 110°F (38°C)
Current Draw & Voltage	0.5 Amperes 110 Volts

Control Valve Function and Cycles of Operation

This glass filled Noryl1 (or equivalent) fully automatic control valve is designed as the primary control center to direct and regulate all cycles of a downflow regeneration water softener or filter.

The time clock control valve can be set to perform downflow regeneration or simply backwash. The time clock control valve has two calendar options for regeneration frequency:

1. An option where the user can choose the number of days (1-99) between each regeneration; and
2. A seven-day option where the user can choose which day(s) of the week a regeneration should occur.

The control valve is compatible with a variety of regenerants and resin cleaners. The control valve is capable of routing the flow of water in the necessary paths to regenerate or backwash water treatment systems. The control valve regulates the flow rates for backwashing, rinsing, and the replenishing of treated water into a regenerant tank, when applicable.

The control valve uses no traditional fasteners (e.g. screws); instead clips, threaded caps and nuts and snap type latches are used. Caps and nuts only need to be firmly hand tightened because radial seals are used. Tools required to service the valve include one small blade screw driver, one large blade screw driver, pliers and a pair of hands. A plastic wrench is available which eliminates the need for screwdrivers and pliers. Disassembly for servicing takes much less time than comparable products currently on the market. Control valve installation is made easy because the distributor tube can be cut ½” above to ½” below the top of tank thread. The distributor tube is held in place by an o-ring seal and the control valve also has a bayonet lock feature for upper distributor baskets.

The power supply comes with a 15 foot power cord and is designed for use with the control valve. The power supply is for dry location use only. The control valve maintains timekeeping for up to 8 hours if the power goes out and the battery is not depleted. After 8 hours, the only item that needs to be reset is the time of day; valve status and programming are permanently stored in the nonvolatile memory. If a power loss lasts less than 8 hours and the time flashes on and off, the time of day should be reset and the non rechargeable battery should be replaced.

The user can initiate manual regeneration. The user has the option to request the manual regeneration at the delayed regeneration time or to have the regeneration occur immediately. Simultaneously press ▲ and ▼ to start a regeneration at the next delayed regeneration time. If a regeneration is to occur “today” an arrow will point to REGEN. For immediate regeneration, simultaneously press and hold ▲ and ▼ for three seconds. When in regeneration, step through the different regeneration cycles by pressing ▲ or ▼

Introduction

Pre-Installation Checklist

1. A standard electrical outlet (120V/60Hz) must be located within 12' of the installation site.
2. A working floor drain, washer standpipe or suitable location for wastewater discharge should be within 20' of the installation site. (See General Warning #6.)
3. If a working pressure reducing valve is not already installed in the home, then one must be installed on the inlet water line that supplies the water filter. Note: **The warranty is void if the system is exposed to water pressure in excess of 90 psi.**
4. If installed outside, then the temperature at the location of the water filter system must be kept above 40°F.
4. After soldering is complete, cool the pipe and connectors. Slide the plastic nuts (#1) over the brass connectors (#4). Place the white plastic split rings (#2) into the grooves closest to the copper pipe. Next place the O-Rings (#3) into the grooves closest to the end of the brass connectors (#4). Reassemble the completed connection kit onto the bypass assembly. (see General Warning #8)
5. **Plumbing:** As you are facing the front of the filter, the water enters on the right side and exits on the left. Arrows on the valve body indicate direction of flow. Connect the plumbing accordingly. Make sure the bypass valves are in the position shown in *figure 3*.

Installation

1. **Floor space:** Make sure the floor space that has been selected to install the water filter is clean and on a level surface. If it is not level, then a platform that supports the entire bottom surface of the water filter tank must be used, do not use shims.
2. **Connection kit:** The standard connection kit supplied with the water filter will be a brass sweat or pex connection kit (see *Figure 1*). Other kits and vertical adaptors are available.

This kit will consist of the following:

- 2 - Plastic nut 1" quick connect, black (#1)
- 2 - Plastic split ring, white (#2)
- 2 - O-Ring (#3)
- 2 - Brass connector 3/4" or 1" sweat (#4)

3. Solder at least 6" of pipe to the brass connectors before reassembly. (See *Figure 2*)

Figure 2

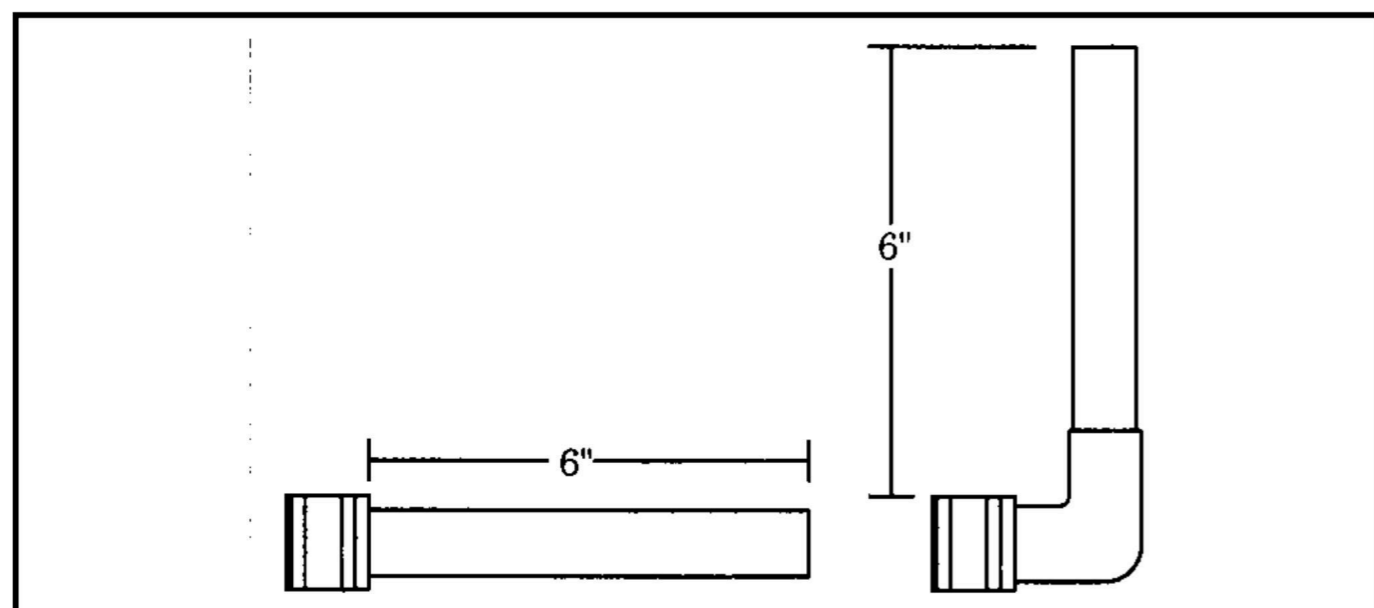
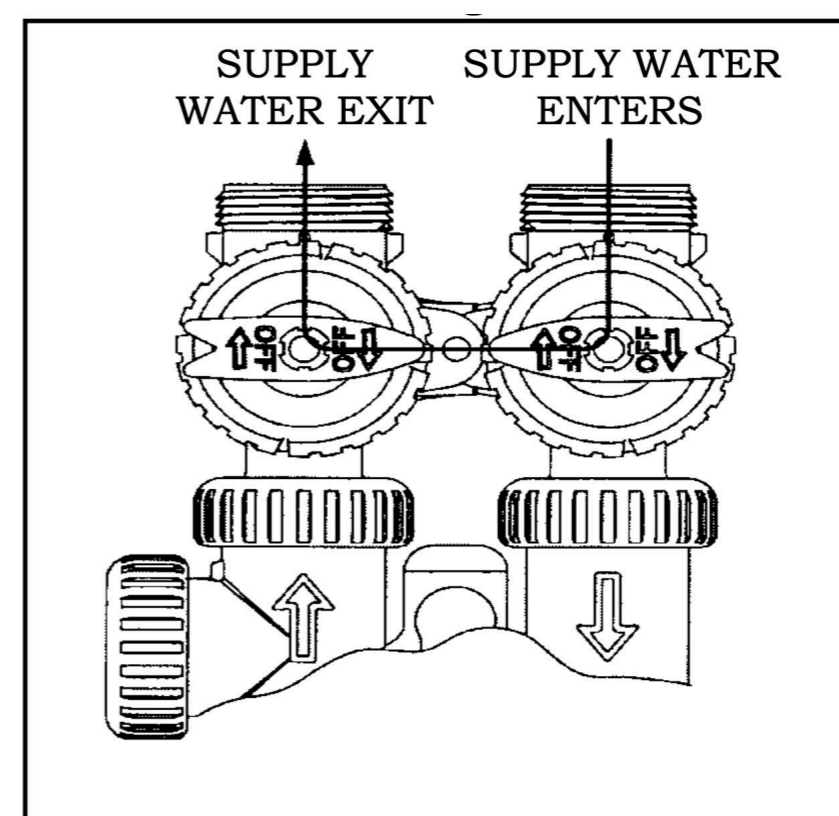

Figure 3



6. All plumbing should be done in accordance with local plumbing codes. (See General Warning #1.)

Installation

- Temporary Drain Tube:** Now that the water filter is connected to the existing plumbing, the drain line may be connected.
- Connecting the drain line:** Slide plastic nut (#3) over the permanent drain tubing and place the polytube insert (#2) into the end of the drain tubing. Insert the drain tubing into the drain elbow fitting (#4) and tighten plastic nut (#3) hand tight plus 1/2 turn with pliers.
Caution: Do Not Over tighten. (See Figure 4)

- The water softener is equipped with a 15-foot power cord with built-in transformer. Plug the power cord into a standard (120V 60Hz) electrical outlet. The motor will start running and in approximately 10 seconds you will see the display (this is normal). The water softener is now ready to be programmed.

Figure 4

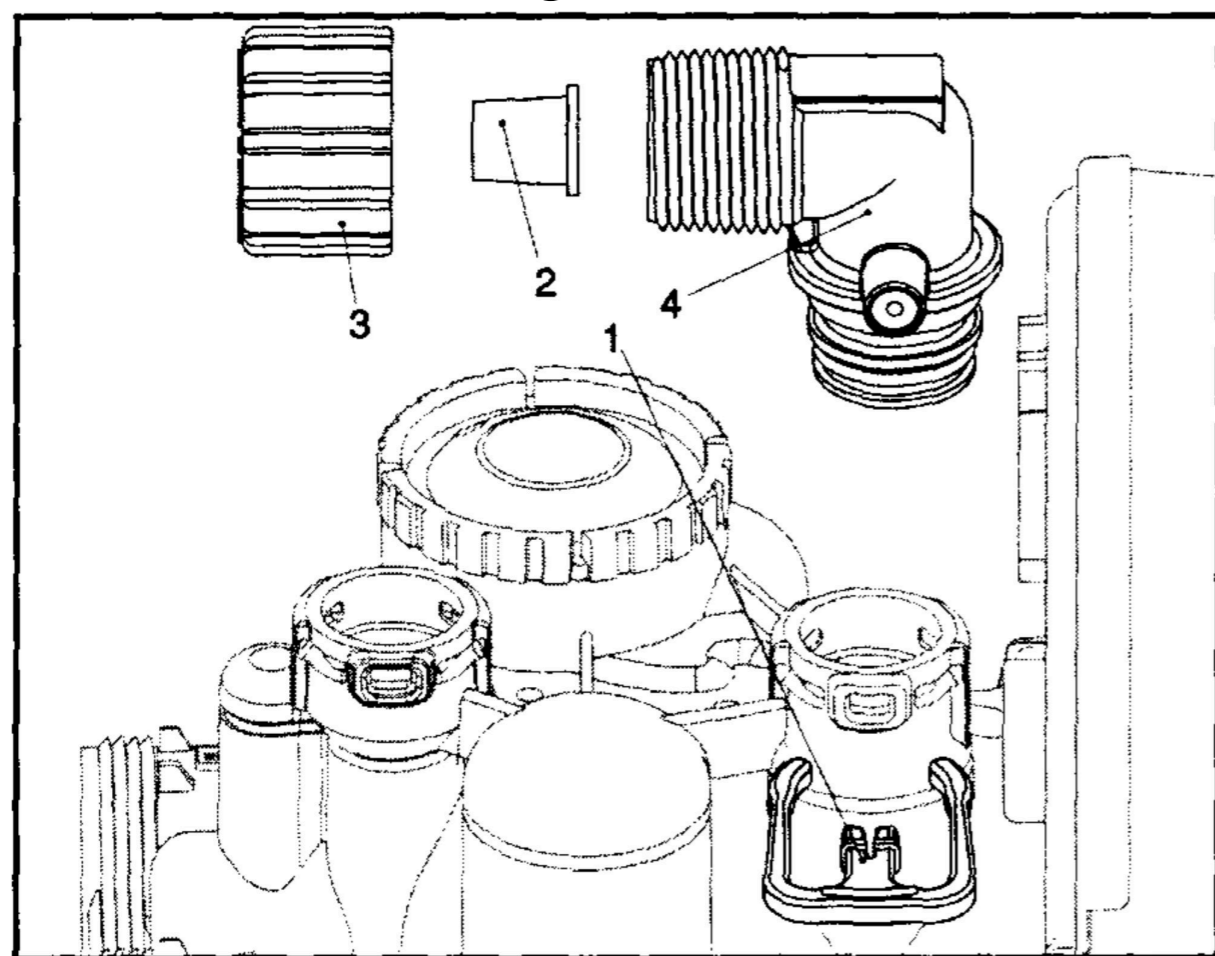

- Drain Line Specs:** If the distance from the water filter to the drain is greater than 30' the drain line size must be increased to 3/4". The threads on the drain elbow fitting are 3/4" male NPT and can be used in lieu of the 1/2" plastic nut and insert. If the drain line must run overhead, the maximum height of the drain line should not exceed 8' above the top of the water softener.
- Air Gap:** The drain line must have an approved air gap to prevent the possibility of a cross connection to the sewer. (See Figure 5)

Figure 5

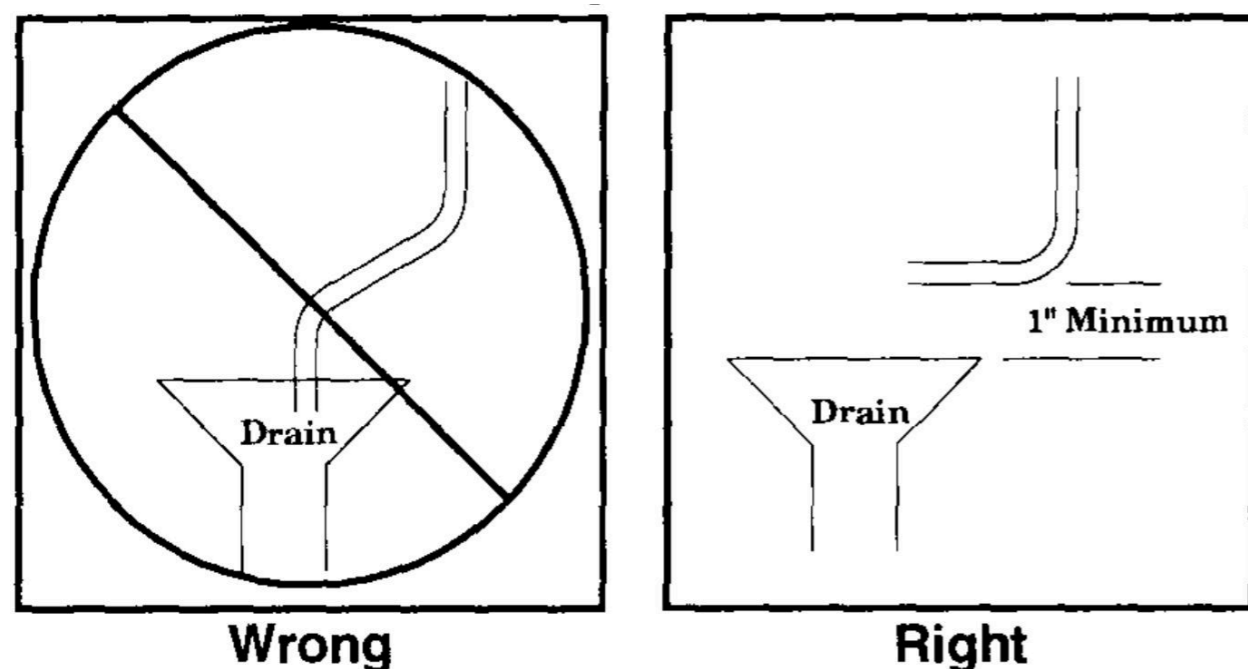

Programming the Controller

1. Setting the Clock: When the controller is first plugged in, the time-of-day display will be flashing.

Step 1: Press and hold the **SET** button.

Step 2: The hour display will now be flashing. Set the correct hour by pressing either the ▲ or the ▼ arrow button. The AM/PM indicator will toggle after the hour reaches 12. Press the **SET** button.

Step 3: The minute display will now be flashing. Set the correct minutes by pressing either the ▲ or the ▼ arrow button. Press the **SET** button. The display will no longer be flashing.

Step 4: Setting the time of regeneration:

Press **SET** and the ▲ arrow simultaneously for 3 seconds and release. The Hour display will now be flashing. Set the correct hour by pressing either the ▲ or the ▼ arrow button. Press **SET** to go to the minute setting

Step 5: The minute display will now be flashing. Set the correct minutes by pressing either the ▲ or the ▼ arrow button. Press the **SET** button.

Step 6: Days to Regenerate. Set the days between regenerations. The allowable range is between 1 to 99. Press **SET** to exit setting

Step 2: Slowly open the red inlet bypass handle by turning it counter clockwise. The handles should now be in the same position as in Figure 1 (Bypass handles may be slightly difficult to turn.)

Figure 1

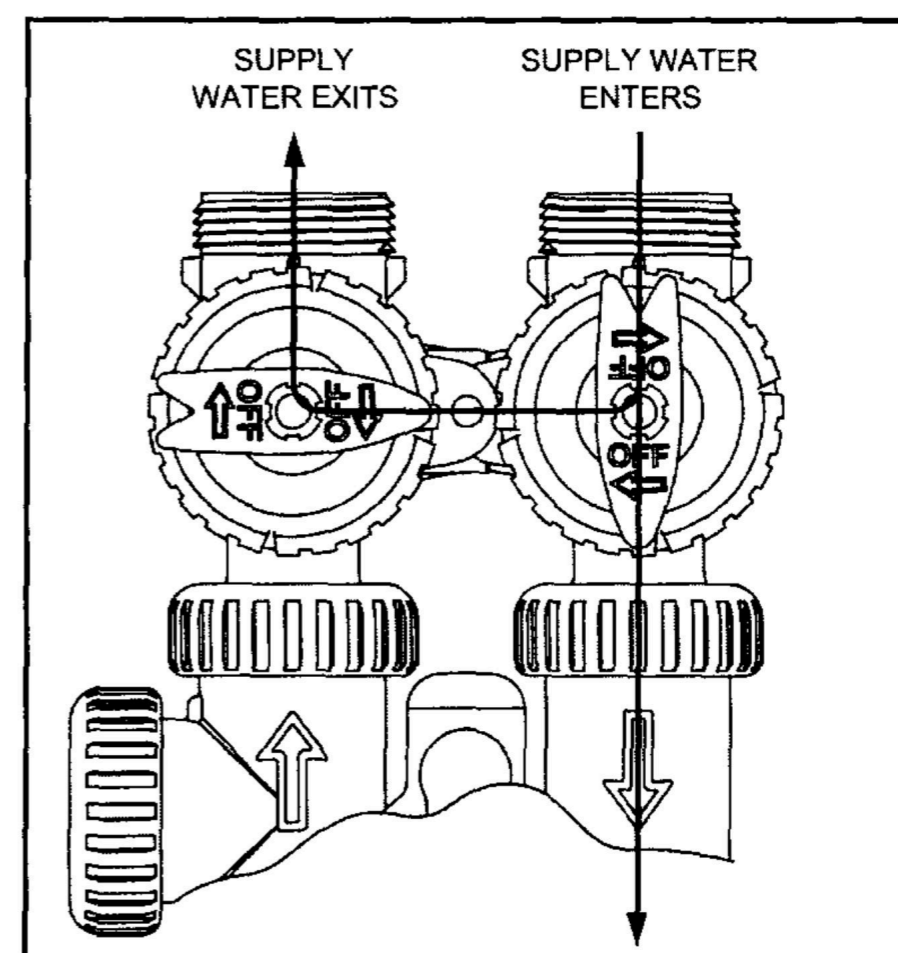

Discolored water and air will begin to run out of the drain hose (this is normal). Leave the controller in this position until the water coming out of the drain hose is clear.

Step 3: Press the ▼ button. The drive motor will run and the "RINSE" display will flash until the drive motor stops.

Step 4: Slowly open the red outlet bypass handle by turning it counter clockwise. The handles should now be in the same position as in Figure 2 (Bypass handles may be slightly difficult to turn.) The water softener is now ready for use.

Figure 2

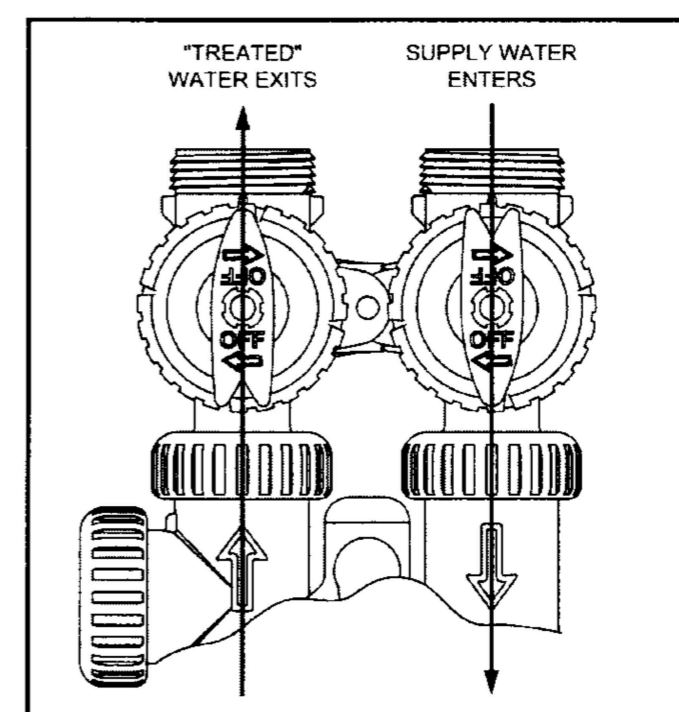

Start -Up Instructions

1. Manually Cycling the Controller:

Step 1: The user can initiate manual regeneration. The user has the option to request the manual regeneration at the delayed regeneration time or to have the regeneration occur immediately. Simultaneously press ▲ and ▼ to start a regeneration at the next delayed regeneration time. If a regeneration is to occur "today" an arrow will point to REGEN. For immediate regeneration, simultaneously press and hold ▲ and ▼ for three seconds. When in regeneration, step through the different regeneration cycles by pressing ▲ or ▼

Bypass Valve Operation

NORMAL OPERATION

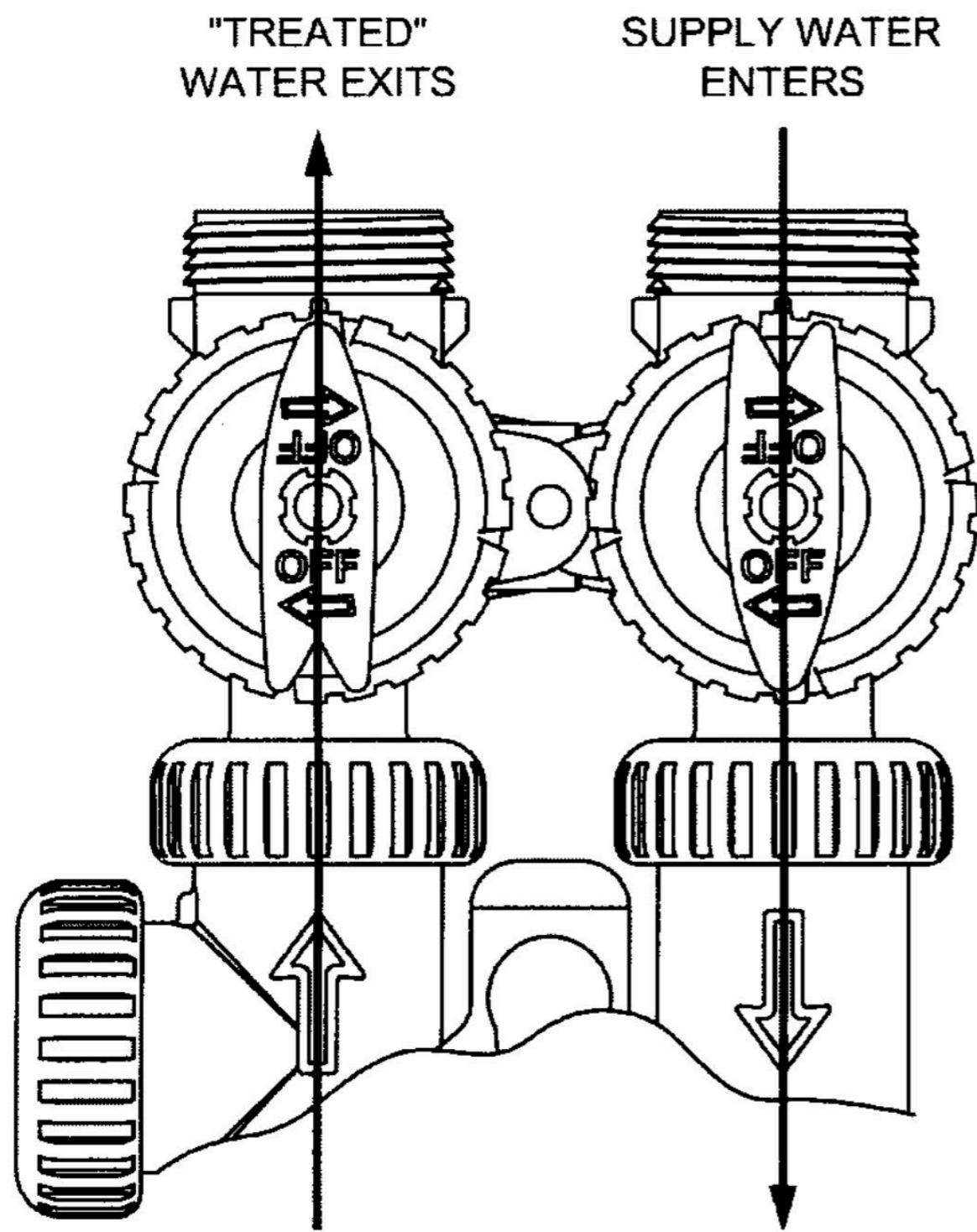

DIAGNOSTIC MODE

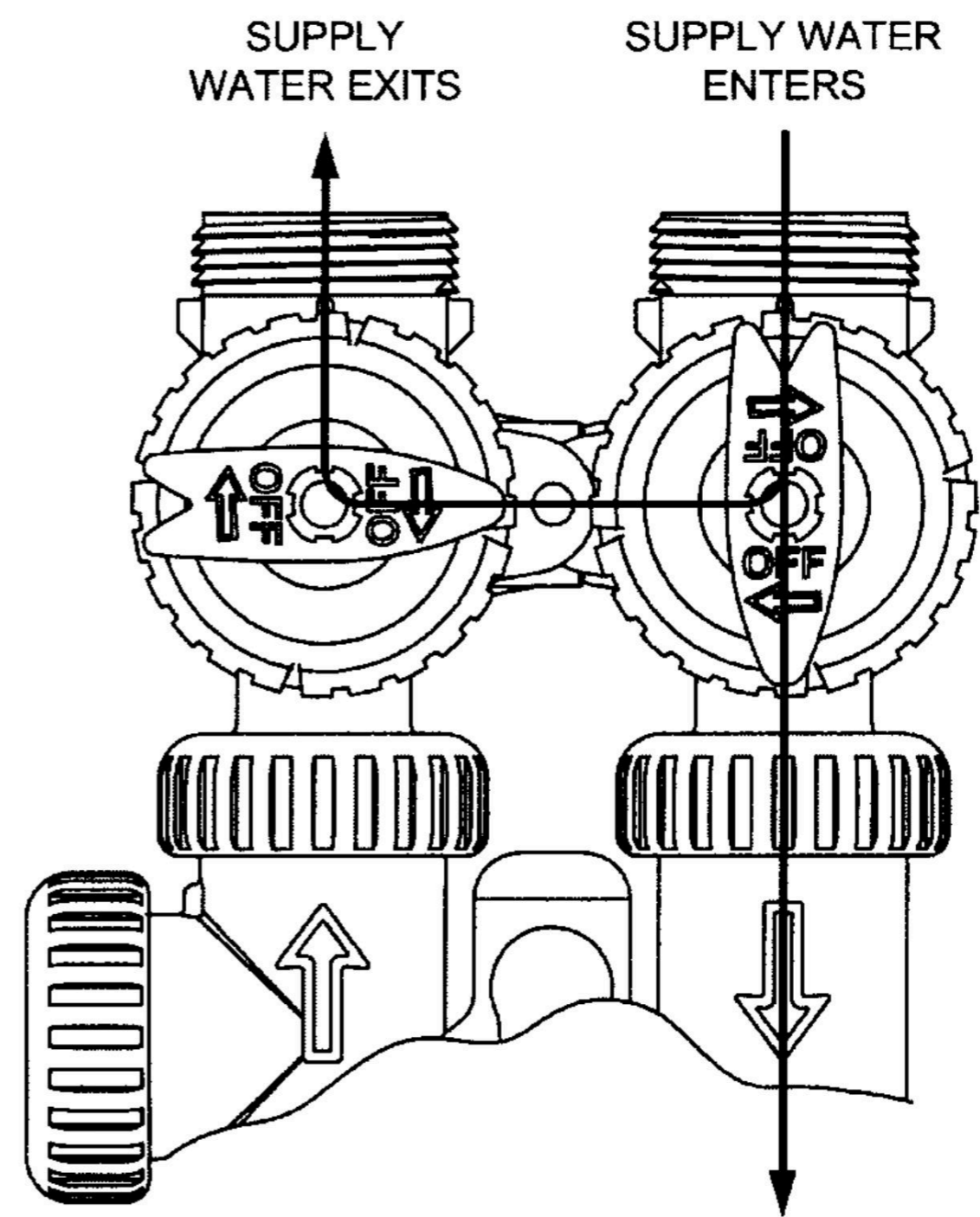

BYPASS OPERATION

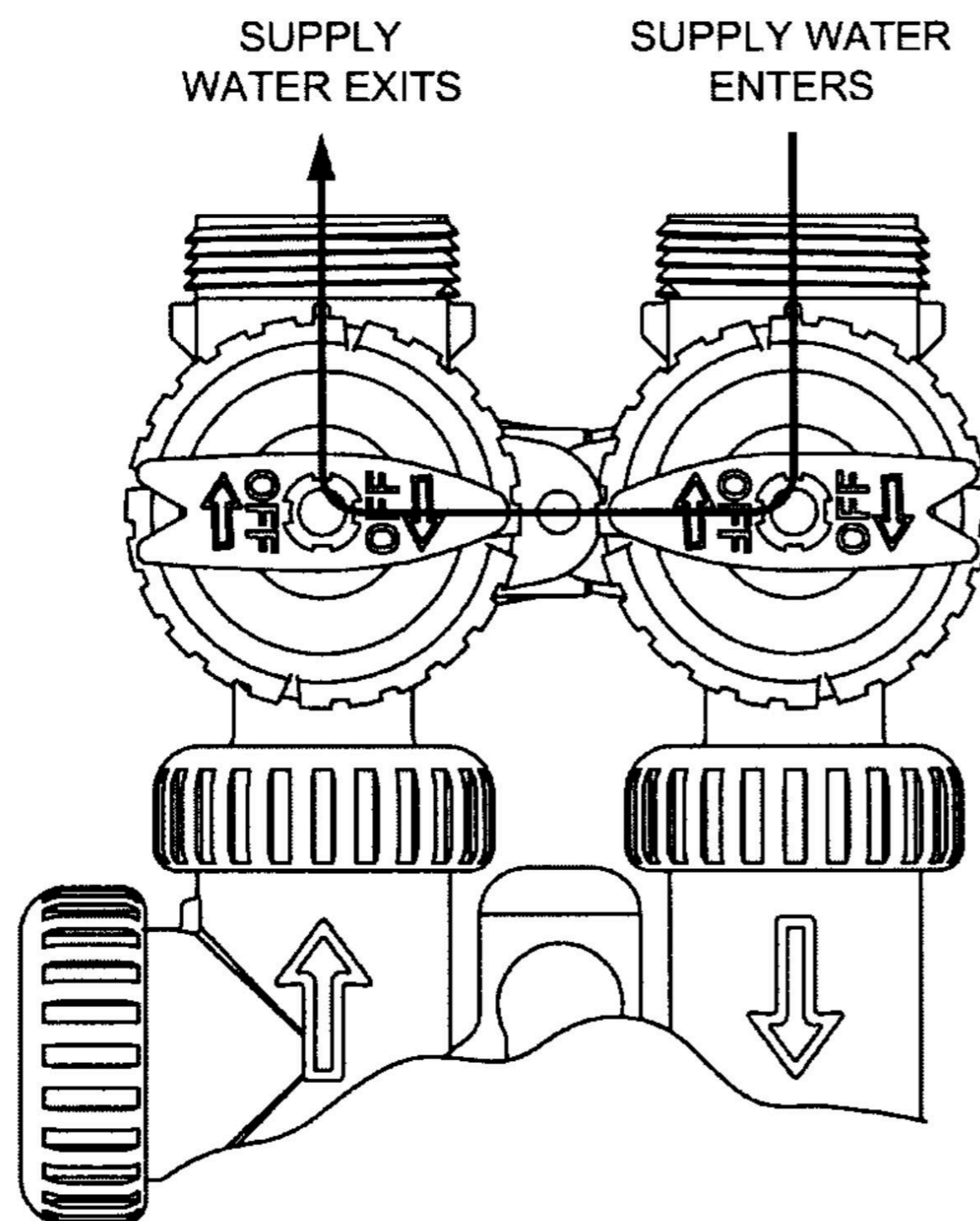

SHUT OFF MODE

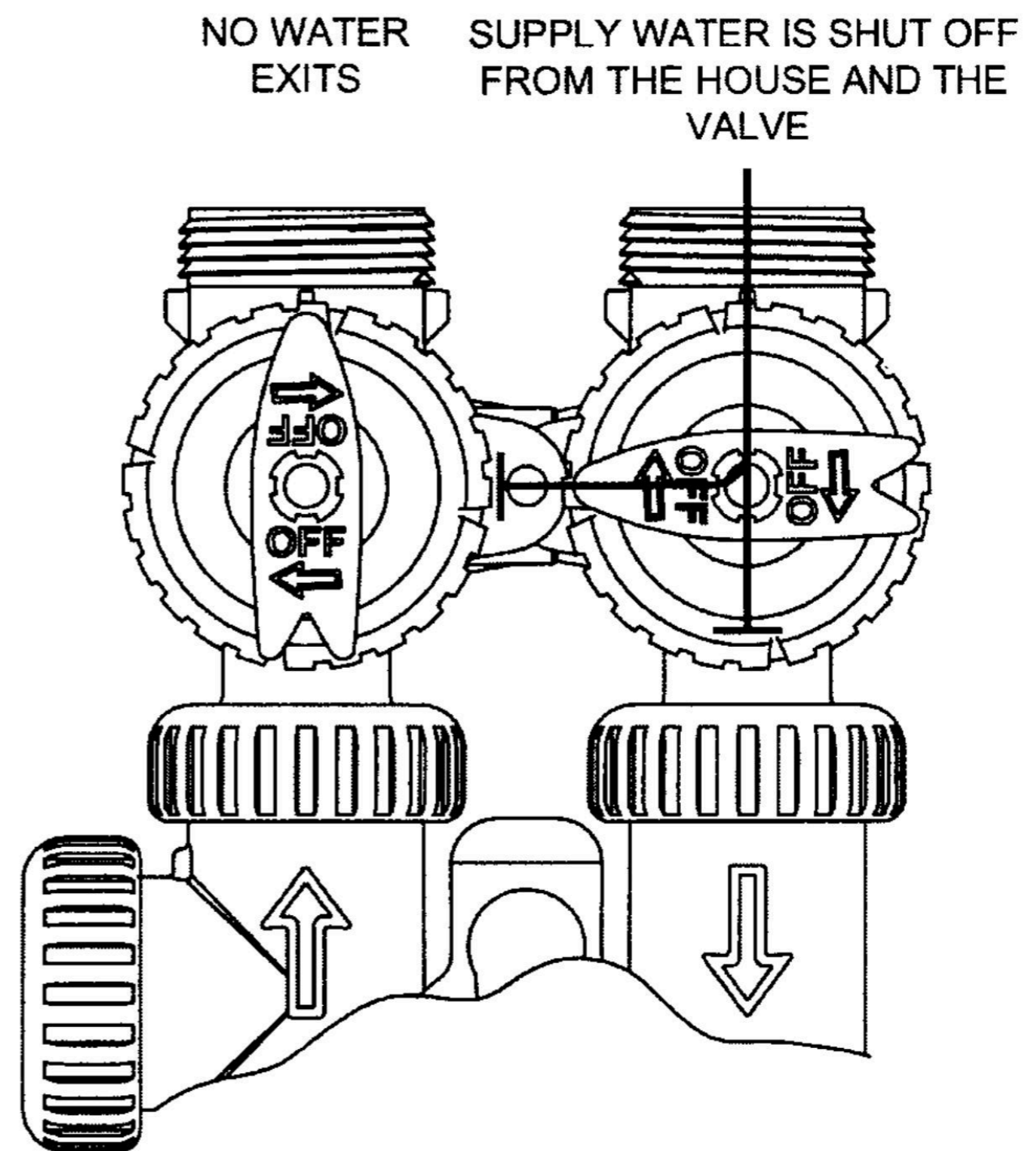

Drawings and Part Numbers

Front Cover and Drive Assembly Breakdown

Drawing No.	Order No.	Description	Quantity
1	V3175TC-01	WS1TC Front Cover Assembly	1
2	V3107-01	WS1 Motor	1
3	V3002-A	WS1 Drive Bracket	1
4	V3818TC-01 BOARD	WS1/125TC-01 PC B 4-Digit Replace	1
5	V3110	WS1 Drive Gear 12x36	3
6	V3109	WS1 Drive Gear Cover	1
Not Shown	V3186-06	WS1 Power Supply US 15VDC HOCP 1	1
	V3186EU-06	WS1 Power Supply EU 15VDC HOCP	1
	V3186UK-06	WS1 Power Supply UK 15VDC HOCP	1
	V3186-01	WS1 Power Cord Only 15FT	1

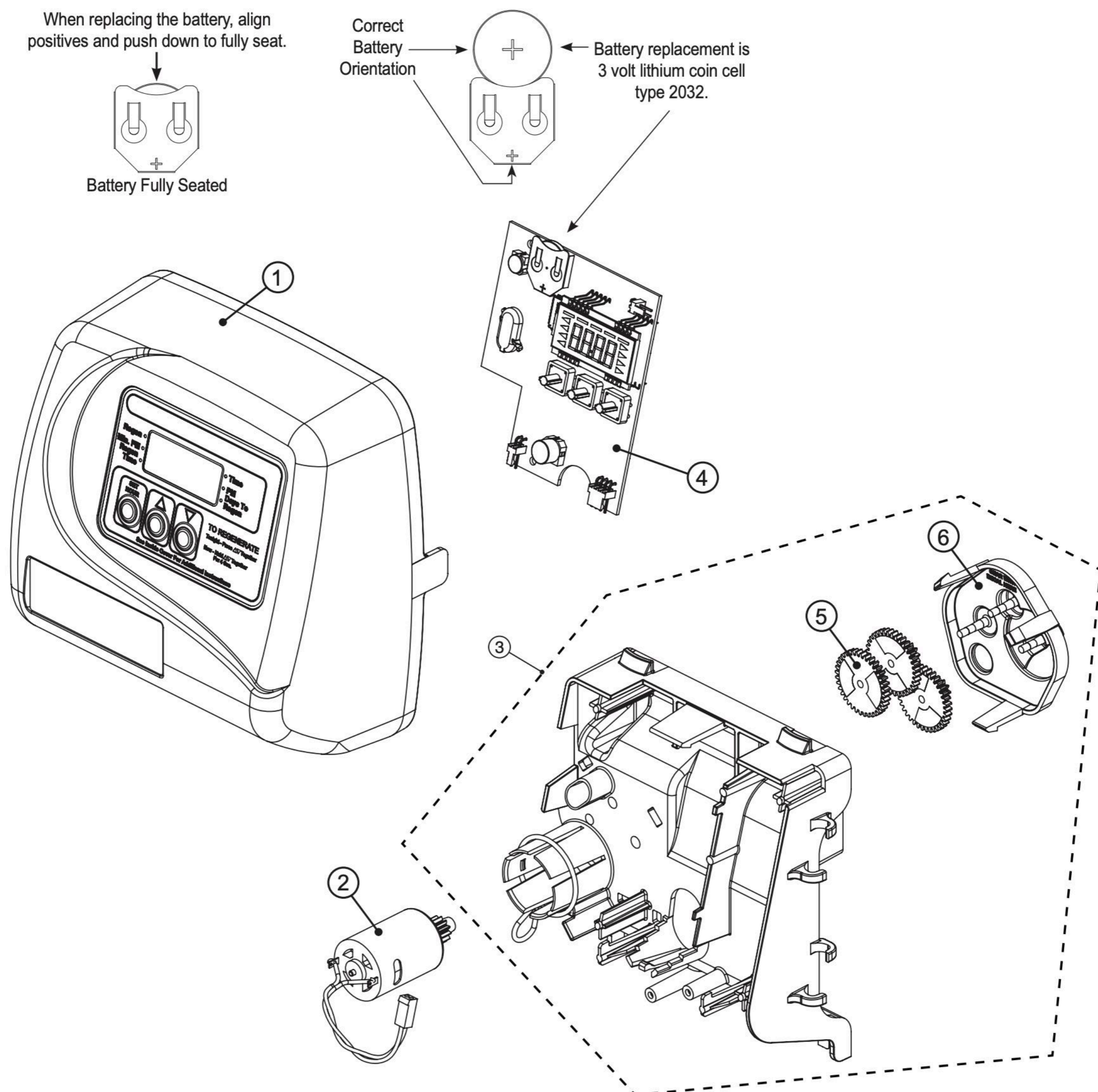

Internal Parts Breakdown

Drawing No.	Order No.	Description	Quantity
1	V3005	WS1 Spacer Stack Assembly	1
2	V3004	Drive Cap ASY	1
3	V3135	O-ring 228	1
4a	V3011*	WS1 Piston Downflow ASY	1
4b	V3011-01*	WS1 Piston Upflow ASY	1
5	V3174	WS 1 Regnerant Piston	1
6	V3180	O-ring 3371	1

***V3011 is labeled with DN and V3011-01 is labeled with UP.**

Note: The regenerant piston is not used in backwash only applications.

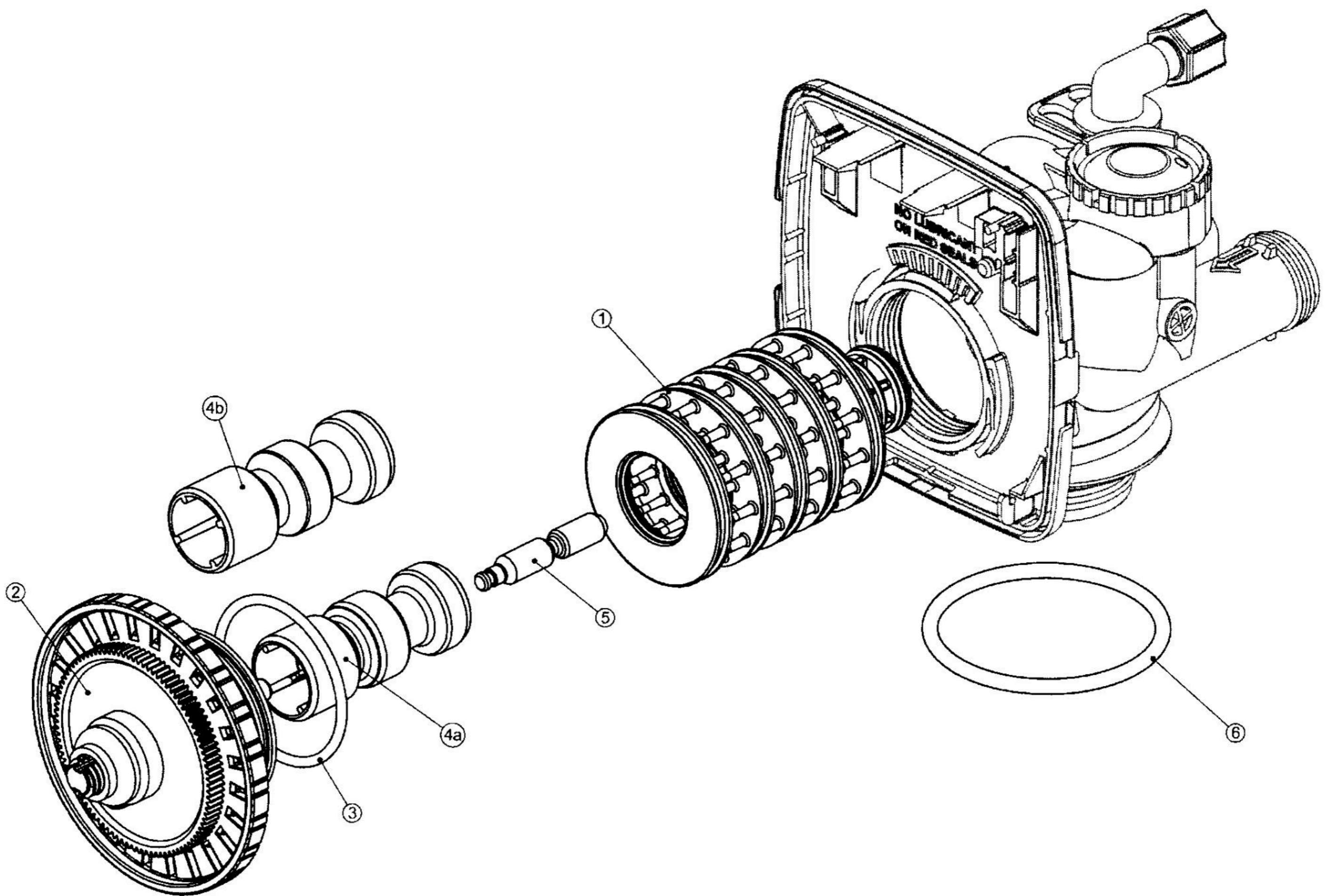

Bypass Assembly Breakdown

Drawing No.	Order No.	Description	Quantity
1	V3151	WS I Nut 1" Quick Connect	2
2	V3150	WS I Slit Ring	2
3	V3105	O-Ring 215	2
4	V3145	WS I Bypass 1" Rotor	2
5	V3146	WS I Bypass Ca	2
6	V3147	WS I Bypass Handle	2
7	V3148	WS I Bypass Rotor Seal Retainer	2
8	V3152	O-ring 135	2
9	V3155	O-ring 112	2
10	V3156	O-ring 214	2

(Not Shown) Order No. V3191-01, Description: WS I Bypass Vertical Adapter Assembly

Order No.	Description	Quantity
V3151	WSI Nut 1" Quick Connect	2
V3150	WSI Slit Ring	2
V3105	O-Ring 215	2
V3191-01	WSI Bypass Vertical Adapter Assembly 2	2

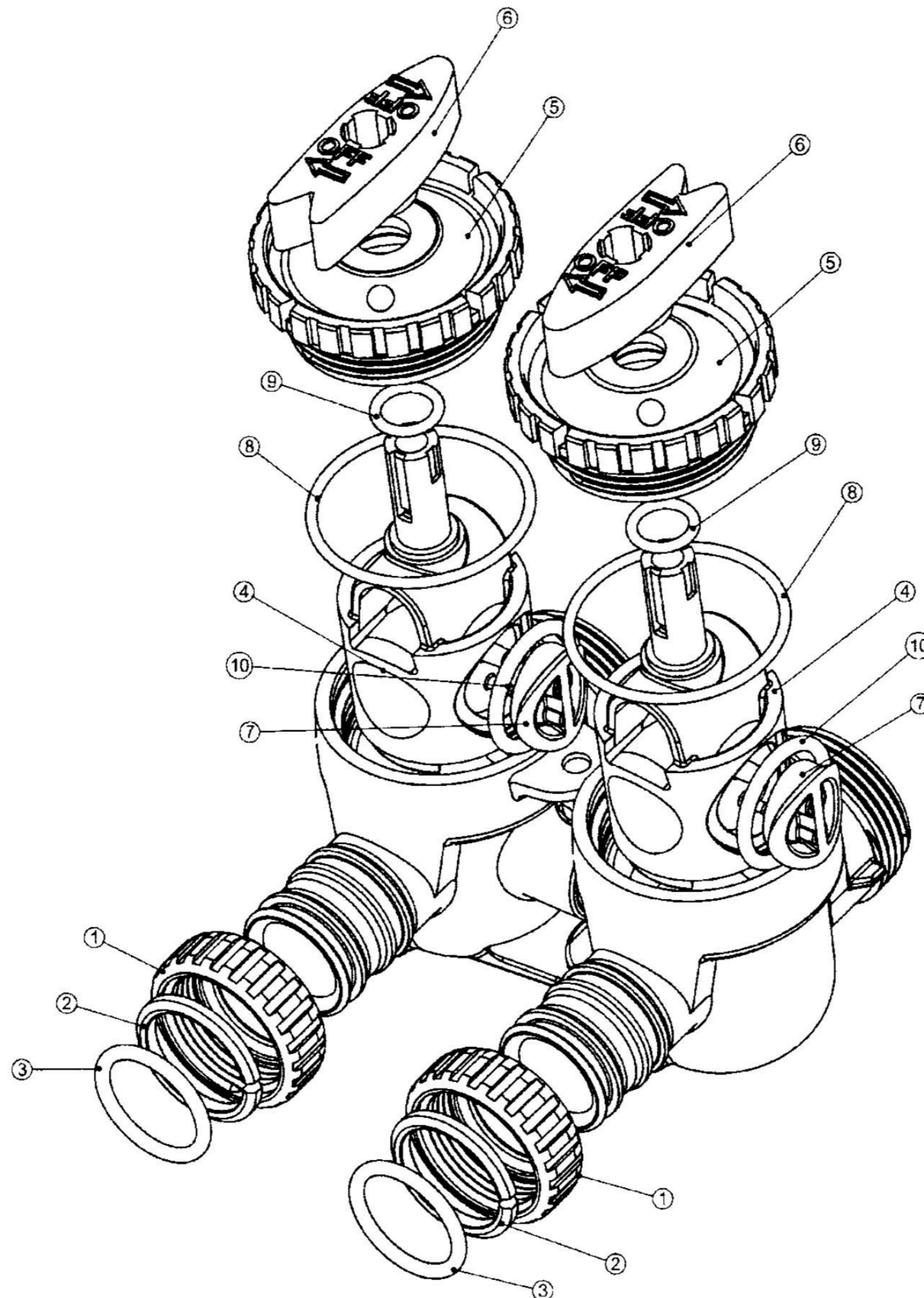

Trouble Shooting Procedures

Problem	Possible Cause	Solution
1. Timer does not display time of day	a. Transformer unplugged	a. Connect power
	b. No electric power at outlet	b. Repair outlet or use working outlet
	c. Defective transformer	c. Replace transformer
	d. Defective PC board	d. Replace PC board
2. Timer does not display correct time of day	a. Switched outlet	a. Use uninterrupted outlet
	b. Power outage	b. Reset time of day
	d. Defective PC board	d. Replace PC board
3. Control valve stalled in regeneration	a. Motor not operating	a. Replace motor
	b. No electric power at outlet	b. Repair outlet or use working outlet
	c. Defective transformer	c. Replace transformer
	d. Defective PC board	d. Replace PC board
	e. Broken drive gear or drive cap assembly	e. Replace drive gear or drive cap assembly
	f. Broken piston retainer	f. Replace drive cap assembly
	g. Broken main or regenerant piston	g. Replace main or regenerant piston

Power Loss

Only the current time of day will need to be reset if power is lost for greater than 8 hours. If power is lost while the system is regenerating, the control will complete regeneration at the point of interruption once power is restored.

Error Messages

If “E1,” “E2,” “E3” or “E4” appears on the display contact the OEM for help. This indicates that the valve did not function properly.

Manufactured with pride in Utah By:



**369 South Mountainway Drive Orem, UT 84058
(801) 426-9243**

TITAN VI CARBON