

TITAN VI BLEND

Up-Flow Filtration System

Installation and Operation Manual



Manufacturer's Warranty

To the original purchaser, the valve body, cation resin, mineral container, and salt storage container carry an unconditional non-prorated 10-year guarantee, replaced F.O.B. Orem, Utah

The water conditioner manufactured by **Holts Water Conditioning** is unconditionally guaranteed against defects in workmanship and materials for a period of **2 year** from the date of original purchase at the original installation site.

Warranty coverage on all moving parts and electronics carry a limited 10 year warranty. Should any part or parts except those listed above prove defective after the initial two-year period from the original date of purchase and installation site, said part or parts will be repaired, rebuilt, or replaced at the manufacturer's option for a maximum charge of \$75.00 F.O.B Orem, Utah, provided the part is returned to the manufactures place of business, with transportation and other charges incurred in replacement or repair of defective parts paid by customer.

Holts Water Conditioning will not be held responsible/liable for Freight/shipping charges, labor/service charges, loss(property or other), or damages caused by a defective part.

The following items will Void this manufacturer's warranty:

- All systems must have main feed water pressure greater than 30 P.S.I. but lower than 90 P.S.I.
- All systems must have water temperature over 34 degrees Fahrenheit and under 90 degrees Fahrenheit. Any vacuum causing reverse flow allowing Hot water to enter any system will Void the Manufacturer's warranty.
- Water entering all systems must be absent any sediment of any type (Not limited to, Sand, Silt, Turbidity), causing Organic loading.
- Water entering any system must have Chlorine and or Chloramine levels below 1 PPM. Warranty does not cover resin bed degradation due to high Chlorine/ Chloramine content.
- Water must have Iron levels below .25ppm. Warranty does not cover Iron fouling
- If any system has been subject to misuse, neglect, alterations, Brown outs, power surges, Direct UV sunlight, misapplication, installation error and/or accident caused by fire, flood, earthquake or any other natural disaster.
- Warranty does not cover systems that have been installed on a water supply of unknown water quality or Microbiologically unsafe.



**369 South Mountainway Drive Orem, UT 84058
(801) 426-9243**

General Warnings

1. The control valve, fittings and/or bypass are designed to accommodate minor plumbing mis-alignments but are not designed to support the weight of a system or the plumbing.
2. Do not use Vaseline, oils, other hydrocarbon lubricants or spray silicone anywhere. A silicon lubricant may be used on black o-rings but is not necessary. **Avoid any type of lubricants, including silicone, on red or clear lip seals.**
3. The nuts and caps are designed to be unscrewed or tightened by hand or with the special plastic wrench. If necessary pliers can be used to unscrew the nut or cap. Do not use a pipe wrench to tighten or loosen nuts or caps. Do not place screwdriver in slots on caps and/or tap with a hammer.
4. Do not use pipe dope or other sealants on threads. Teflon tape must be used on the threads of the 1" NPT elbow or the 1/4" NPT connection and on the threads for the drain line connection. Teflon tape is not necessary on the nut connection or caps because of O-ring seals.
5. After completing any valve maintenance involving the drive assembly or the drive cap assembly and pistons, press and hold NEXT and REGEN buttons for 3 seconds or unplug power source jack from the printed circuit board (black wire) and plug back in. This resets the electronics and establishes the service piston position. The display should flash all wording, then flash the software version (e.g. 154) and then reset the valve to the service position.
6. All plumbing should be done in accordance with local plumbing codes. The pipe size for the drain line should be a minimum of 1/2". Backwash flow rates in excess of 7 gpm or length in excess of 20' require 3/4" drain line.
7. Solder joints near the drain must be done prior to connecting the drain line flow control fitting. Leave at least 6" between the drain line control fitting and solder joints when soldering pipes that are connected on the drain line control fitting. Failure to do this could cause interior damage to the drain line flow control fitting.
8. When assembling the installation fitting package (inlet and outlet), connect the fitting to the plumbing system first and then attach the nut, split ring and O-ring. Heat from soldering or solvent cements may damage the nut, split ring or O-ring. Solder joints should be cool and solvent cements should be set before installing the nut, split ring and O-ring. Avoid getting primer and solvent cement on any part of the o-rings, split rings, bypass valve or control valve.
9. Plug into an electrical outlet. Note: All electrical connections must be connected according to local codes. (Be certain the outlet is uninterrupted.)
10. Install grounding strap on metal pipes.

Table 1
System Specifications

Minimum/Maximum Operating Pressures	20 psi (138 kPa) – 90 psi (621 kPa)
Minimum/Maximum Operating Temperatures	40°F (4°C) – 110°F (38°C)
Current Draw & Voltage	0.5 Amperes 110 Volts

Introduction

Pre-Installation Checklist

1. A standard electrical outlet (120V/60Hz) must be located within 12' of the installation site.
2. A working floor drain, washer standpipe or suitable location for wastewater discharge should be within 20' of the installation site. (See General Warning #6.)
3. If a working pressure reducing valve is not already installed in the home, then one must be installed on the inlet water line that supplies the water softener.
Note: The warranty is void if the system is exposed to water pressure in excess of 90 psi.
4. If installed outside, then the temperature at the location of the water softener system must be kept above 40°F.

Installation

1. **Floor space:** Make sure the floor space that has been selected to install the water softener is clean and on a level surface. If it is not level, then a platform that supports the entire bottom surface of the brine tank must be used, do not use shims.
2. **What to bypass:** A typical installation would include bypassing the outside hose bibs. The cold water feeding the kitchen sink may or may not be bypassed depending upon preference.
3. **Connection kit:** The standard connection kit supplied with the water softener will be a brass sweat connection kit (see Figure 1). Other kits and vertical adaptors are available.

This kit will consist of the following:

- 2 - Plastic nut 1" quick connect, black (#1)
- 2 - Plastic split ring, white (#2)
- 2 - O-Ring (#3)
- 2 - Brass connector 3/4" or 1" sweat (#4)

Figure 1

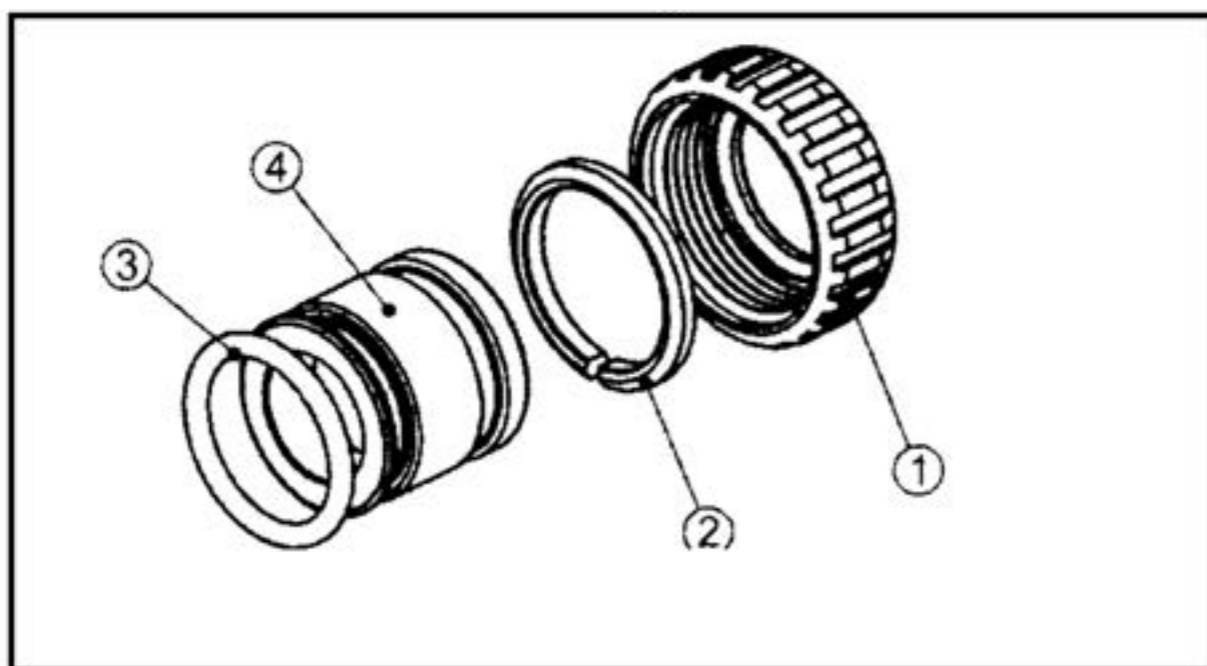

4. Solder at least 6" of pipe to the brass connectors before reassembly. (See Figure 2)

Figure 2

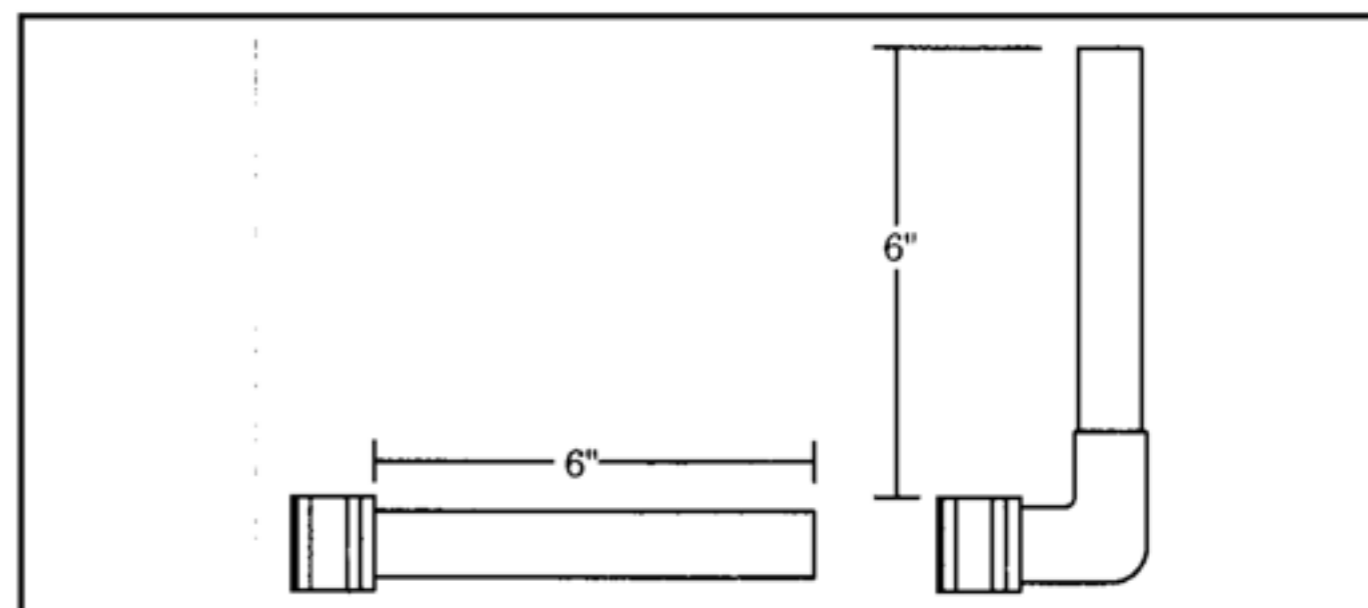

5. After soldering is complete, cool the pipe and connectors. Slide the plastic nuts (#1) over the brass connectors (#4). Place the white plastic split rings (#2) into the grooves closest to the copper pipe. Next place the O-Rings (#3) into the grooves closest to the end of the brass connectors (#4). Reassemble the completed connection kit onto the bypass assembly. (see General Warning #8)
6. **Plumbing:** As you are facing the front of the softener, the water enters on the right side and exits on the left. Arrows on the valve body indicate direction of flow. Connect the plumbing accordingly. Make sure the bypass valves are in the position shown in figure 3.

Figure 3

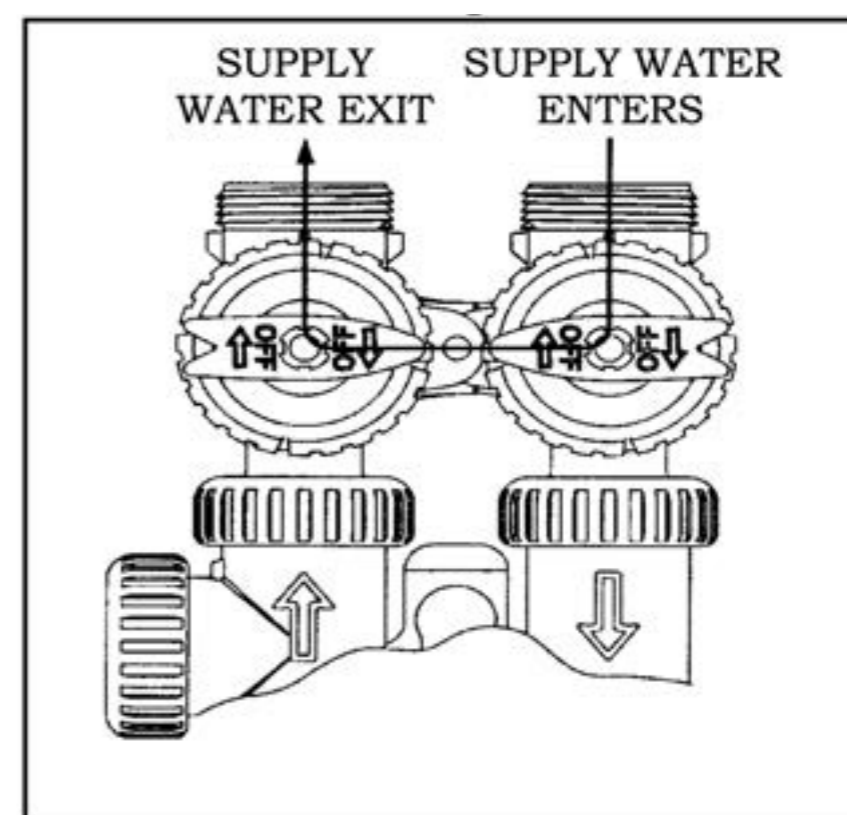

7. All plumbing should be done in accordance with local plumbing codes. (See General Warning #1.)

Installation

8. **Connecting the drain line:** Slide plastic nut (#3) over the permanent drain tubing and place the polytube insert (#2) into the end of the drain tubing. Insert the drain tubing into the drain elbow fitting (#4) and tighten plastic nut (#3) hand tight plus 1/2 turn with pliers.

Caution: Do Not Over tighten. (See Figure 4)

Figure 4

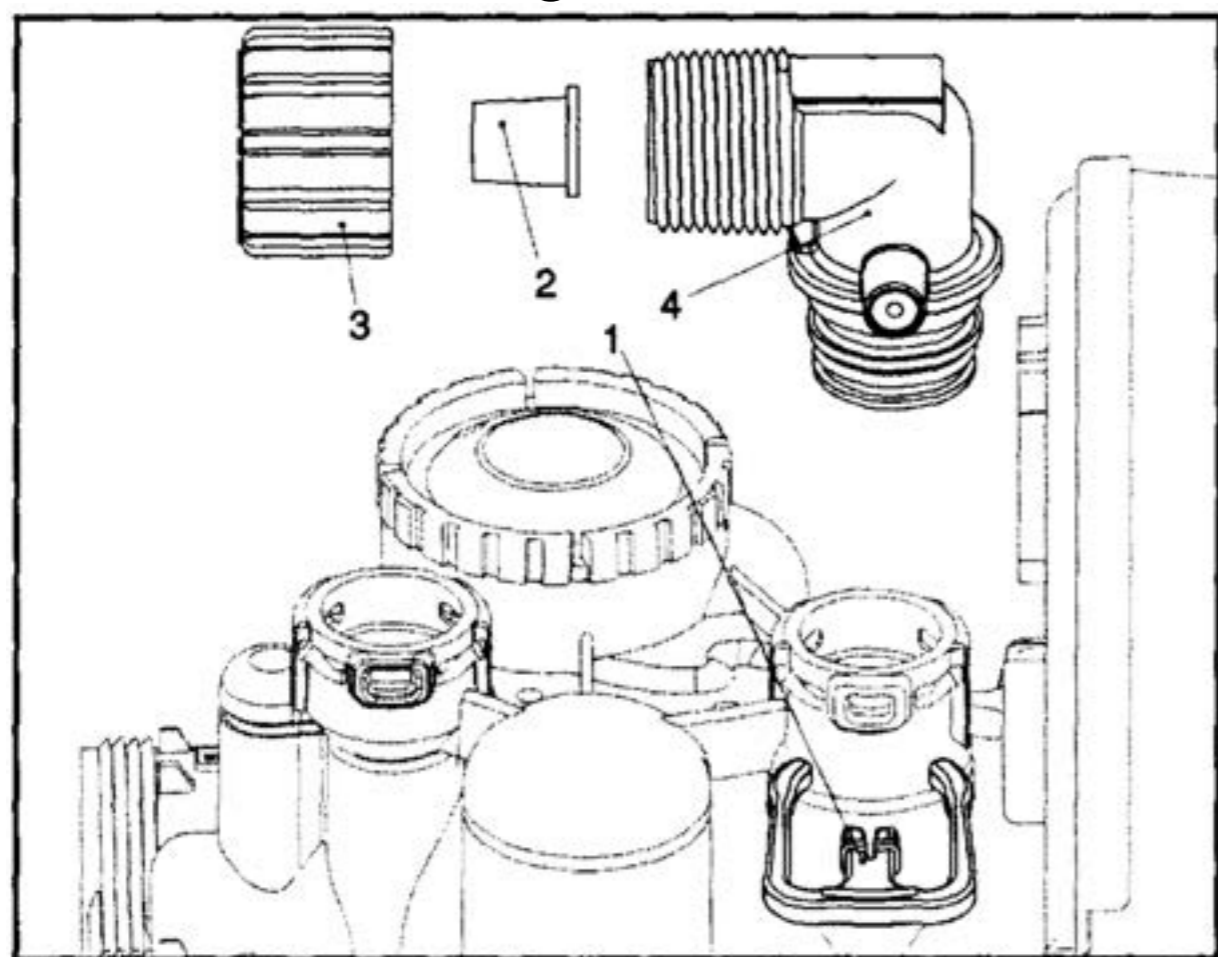

9. **Drain Line Specs:** If the distance from the water softener to the drain is greater than 20' the drain line size must be increased to 3/4". The threads on the drain elbow fitting are 3/4" male NPT and can be used in lieu of the 1/2" plastic nut and insert. If the drain line must run overhead, the maximum height of the drain line should not exceed 8' above the top of the water softener.

10. **Air Gap:** The drain line must have an approved air gap to prevent the possibility of a cross connection to the sewer. (See Figure 5)

Figure 5

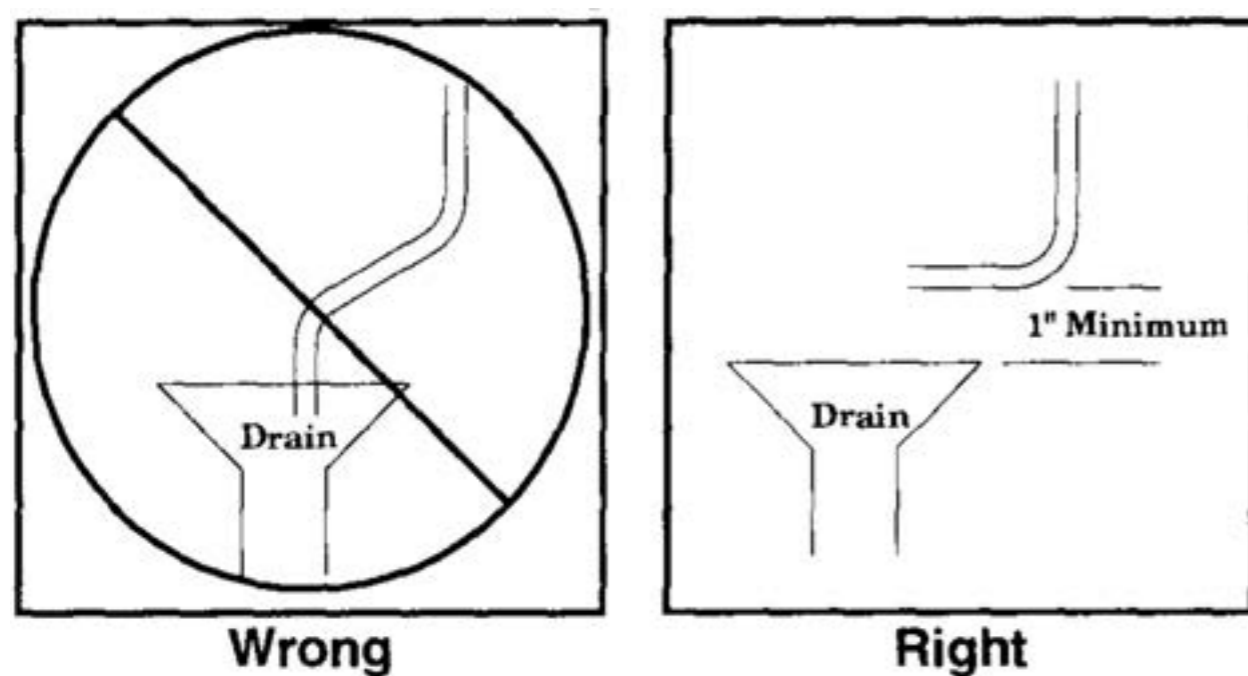

11. **Connecting the overflow line:** The brine overflow fitting is located on the outside of the salt container approximately 12" down from the top. Connect 1/2" drain tubing to the overflow fitting and run it to the nearest floor drain. Remember, this line is a gravity flow line and cannot be run overhead, or connected to a drain that is higher than the overflow fitting and it is never to be connected to the drain line from the valve.

12. **Connecting the brine line to the control valve:** A 3/8" brine line approximately 4' long is inside the salt container, insert (#2) is attached to the brine clip on the valve. (See Figure 6) Unscrew the brine nut (#3) and slide it over the end of the brine line then insert the tube insert #2 in the end of the 3/8" brine line. Insert the brine line into the brine fitting. (#4) and tighten the brine nut (#3) hand tight plus 1/2 turn with pliers
- Caution:** Do Not Overtighten.

Figure 6

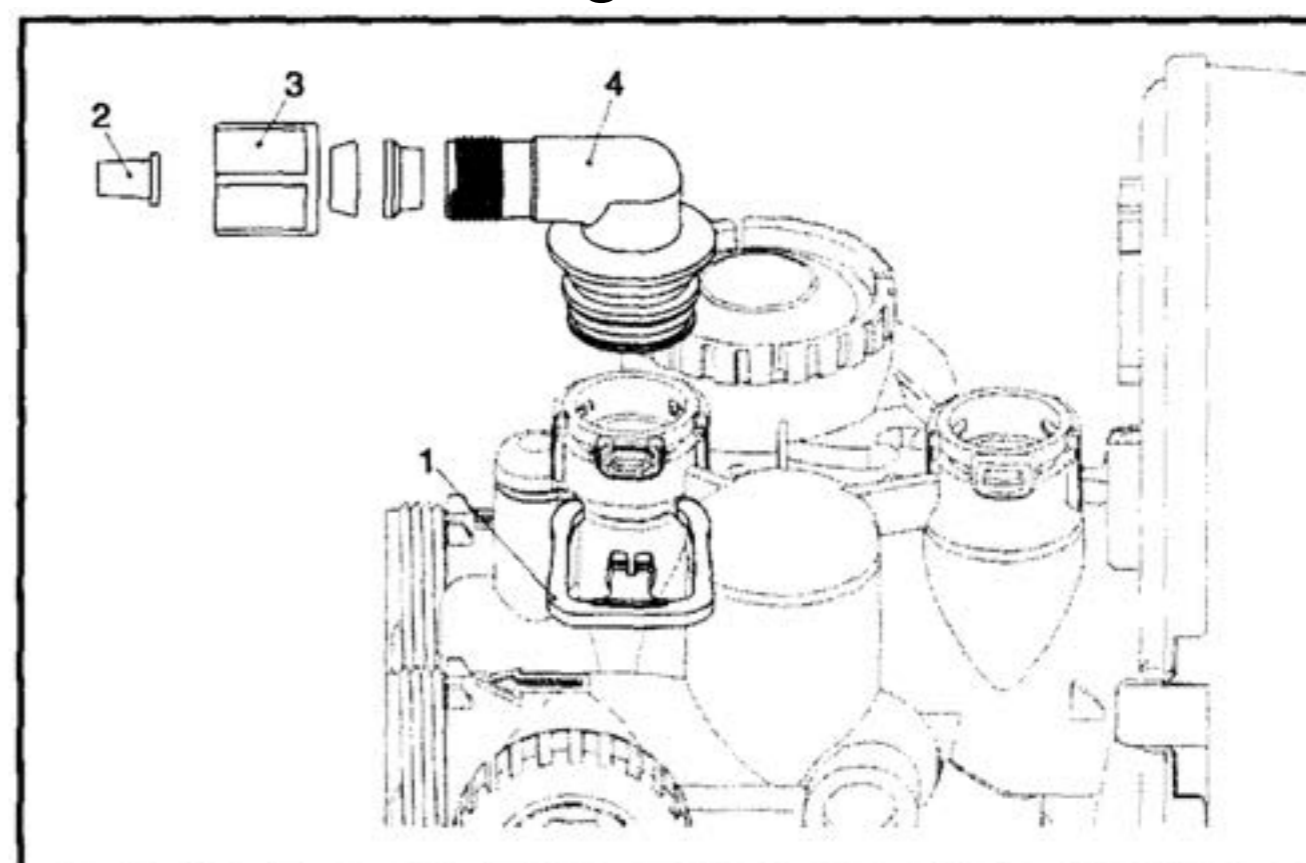

13. **Connecting the 3/8" brine line to the brine tank:** Insert tube into the fitting. Fitting grips before it seals. Ensure that the tube is inserted to the tube stop. The tubing should go into the fitting approximately 3/4".



Once the tubing has been inserted into the fitting pull on the tube to ensure that it is secure.

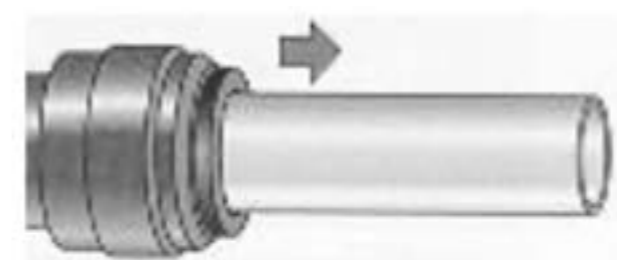

14. The water softener is equipped with a 15-foot power cord with built-in transformer. Plug the power cord into a standard (120V 60Hz) electrical outlet. The motor will start running and in approximately 10 seconds you will see the display (this is normal). The water softener is now ready to be programmed.

Programming

Programming the Controller

1. **Setting the Clock:** When the controller is first plugged in, the time of day display will be flashing.

Step 1: Press NEXT until time of day screen is displayed then, press and hold the ∇ arrow until SET TIME is displayed and the hour flashes.



Step 2: Set the correct hour by pressing either the Δ or the ∇ arrow button. Press the NEXT button.

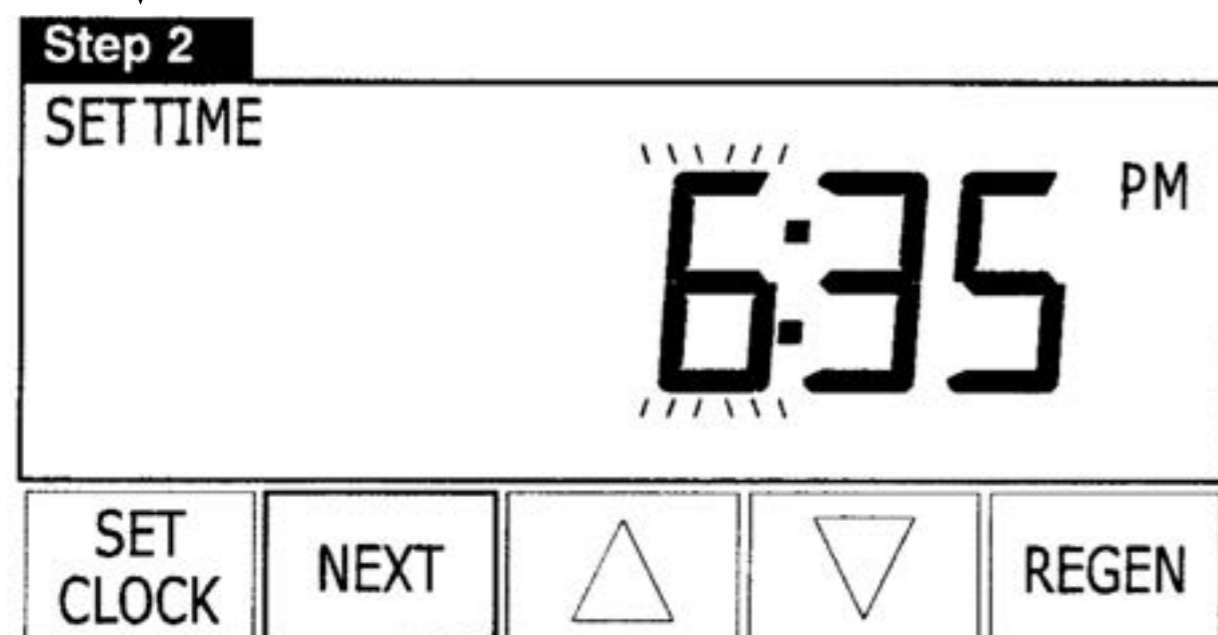

Step 3: Set the correct minutes by pressing either the Δ or the ∇ arrow. Press the NEXT button. The screen will return to the User Display Screen.

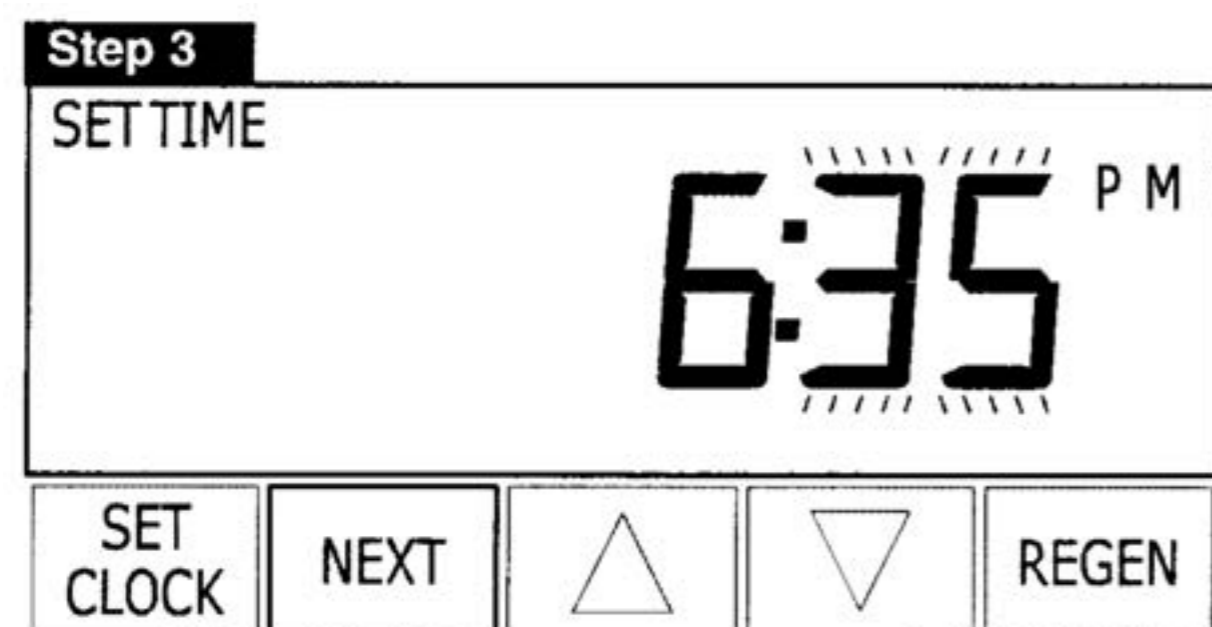

2. **Setting the Water Hardness, Day Override and regeneration times:**

Step 1: Press and hold the NEXT button and the Δ button at the same time for approximately 2 seconds to access hardness setting.

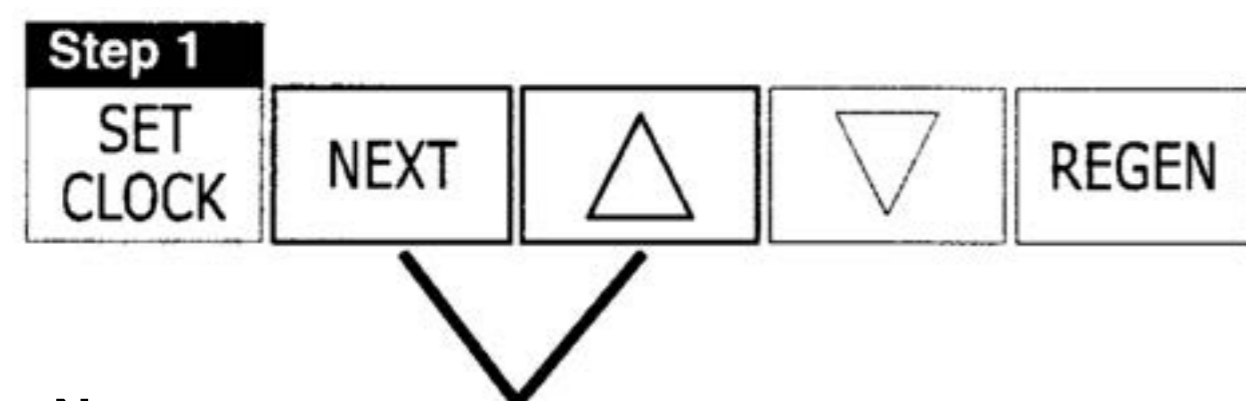

Notes:

1. When in operation, the display can show either time of day or capacity remaining by pressing the **NEXT** button.
2. If the system has called for a regeneration at the preset time, the words **REGEN TODAY** will appear on the display.
3. When water is flowing through the system the word "Softening" flashes on the display.

Step 2 Setting the Hardness: The "SET HARDNESS" display will now be flashing. Set the correct raw water hardness by pressing either the Δ or the ∇ arrow button. If you do not know the water hardness for your location, contact your water treatment representative for this information. Press the NEXT button.

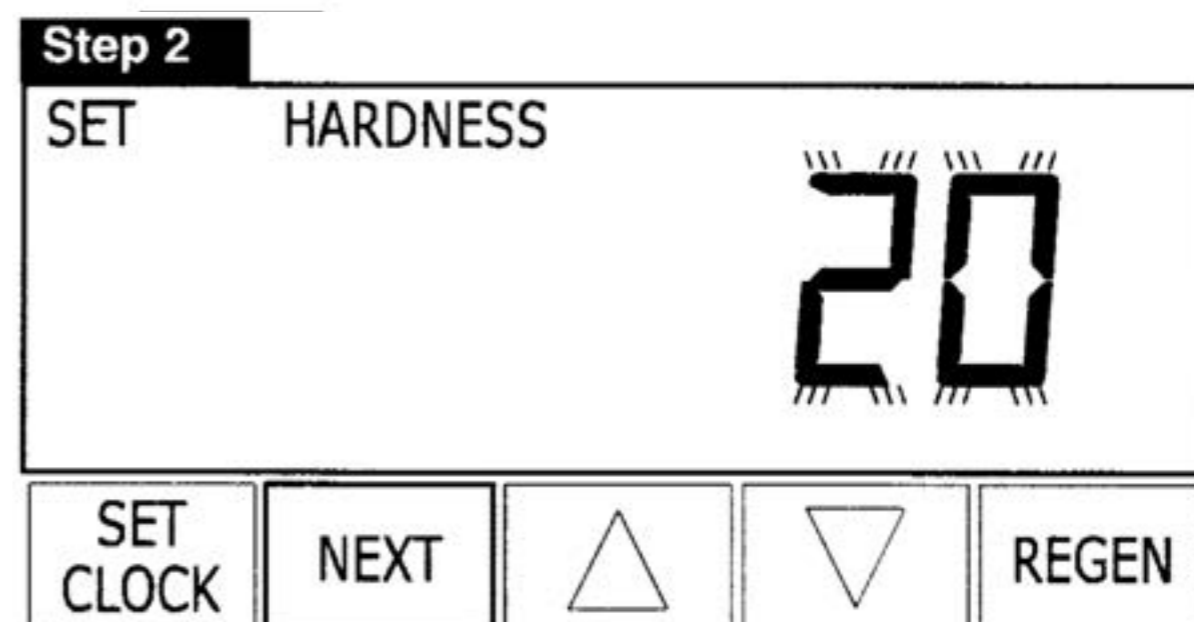

Step 3 Day Override: This means a regeneration will be forced after a preset number of days has passed regardless of water usage. The default is 14 days and can be adjusted with the up and down button. Press NEXT button

Step 4 Setting the time of regeneration: The hour display will now be flashing. Set the correct hour by pressing either the Δ or the ∇ arrow button. The AM/PM indicator will toggle after the hour reaches 12. The default setting for this option is 2:00 AM. Press the NEXT button.

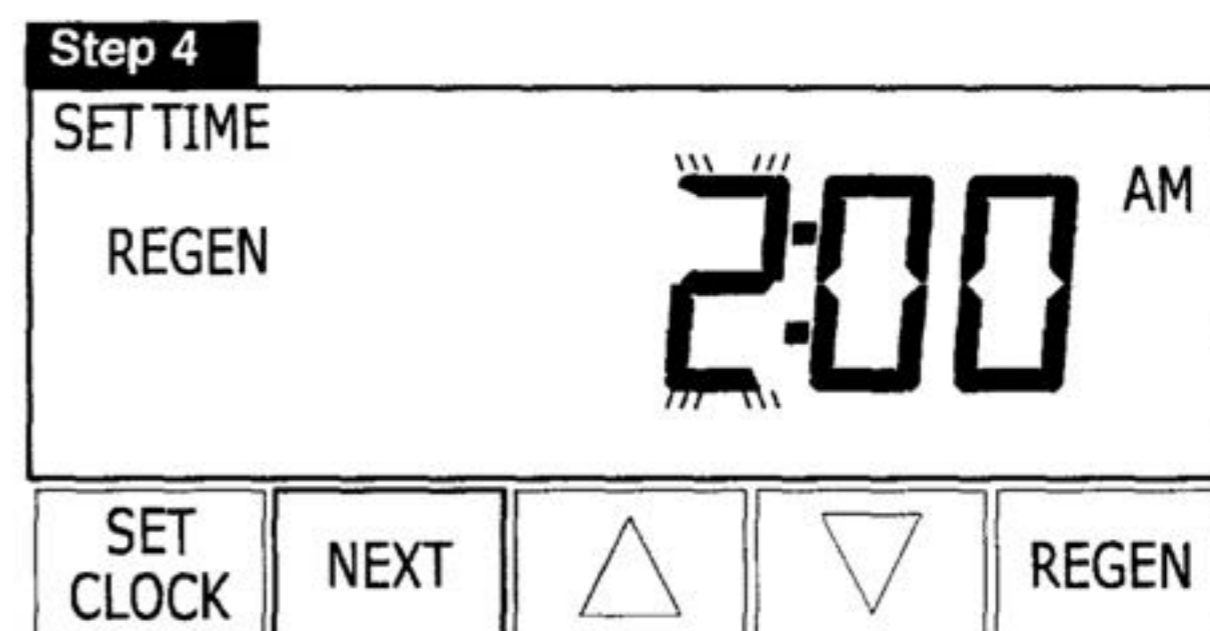

Step 5: The minute display will now be flashing. Set the correct minutes by pressing either the Δ or the ∇ arrow button. Press the NEXT button to exit the programming.

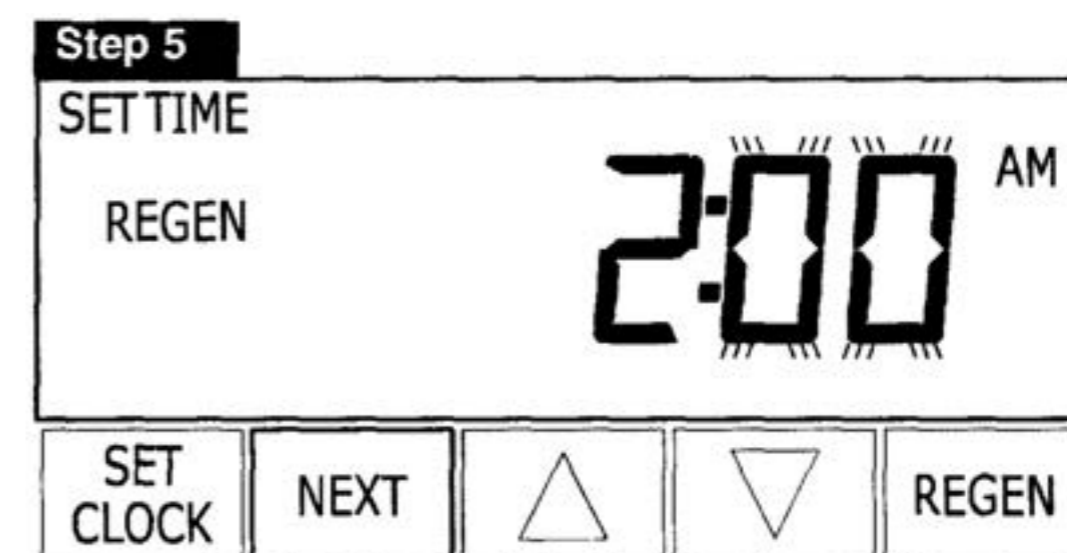

The display will no longer be flashing and programming is complete.

Start -Up Instructions

- 1. Adding Salt to Salt Container:** It is recommended that you add at least 2 bags of salt to the salt container at this time.
- 2. Manually Cycling the Controller:**

Step 1: Initiate a manual regeneration by pressing and holding the REGEN button until you hear the drive motor turn on (approx. 6 sec.). The "BACKWASH" display will flash until the motor stops running. The controller is now in the backwash cycle.

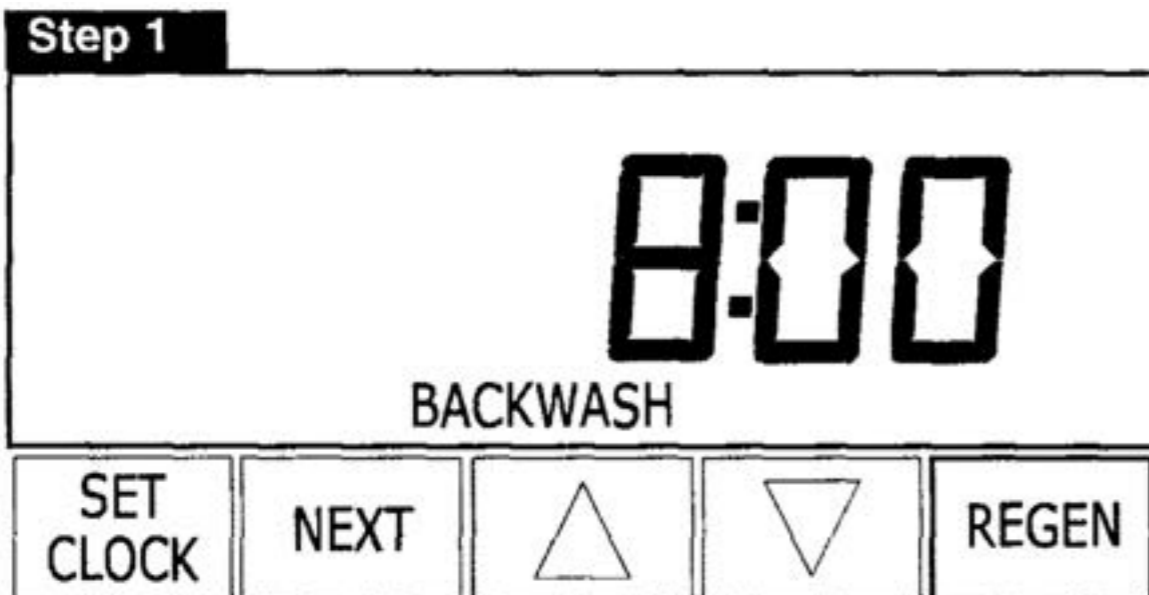

Step 2: Slowly open the red inlet bypass handle by turning it counter clockwise. The handles should now be in the same position as in Figure 1 (Bypass handles may be slightly difficult to turn.)

Figure 1

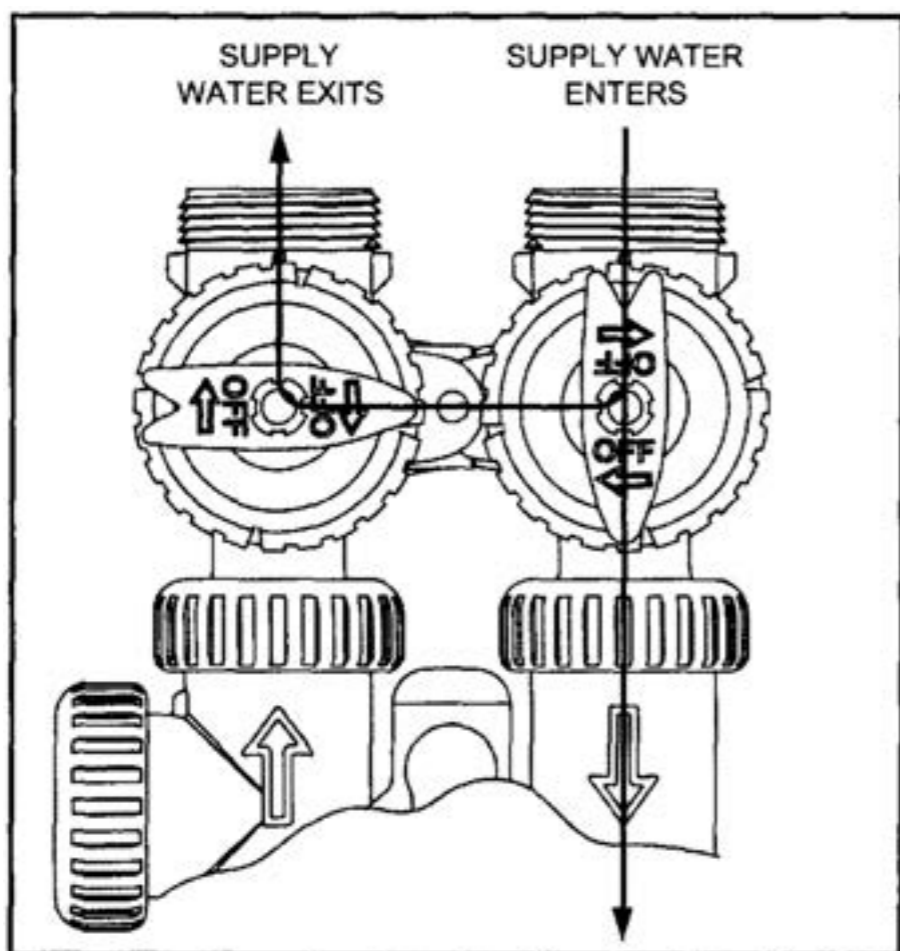

Discolored water and air will begin to run out of the drain hose (this is normal). Leave the controller in this position until the water coming out of the drain hose is clear.

Step 3: Press the REGEN button. The drive motor will run and the "BRINE" display will flash until the drive motor stops.



Step 4: Press the REGEN button. The drive motor will run and the 2nd "BACKWASH" display will flash until the drive motor stops.

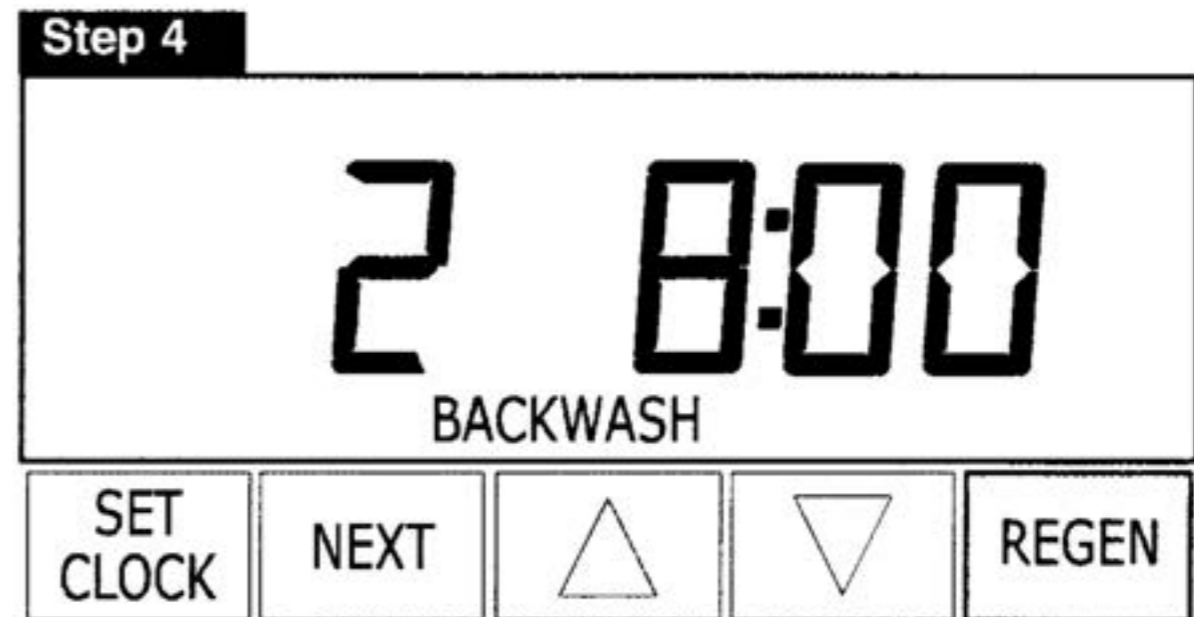

Step 5: Press the REGEN button. The drive motor will run and the "RINSE" display will flash until the drive motor stops.

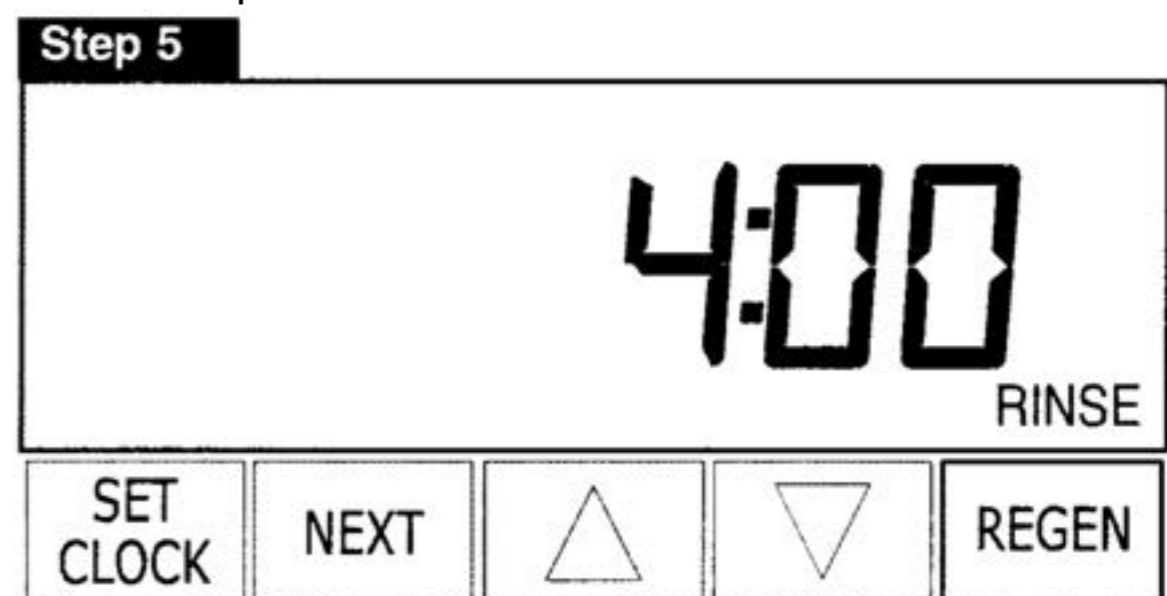

Step 6: Press the REGEN button. The drive motor will run and the FILL display will flash until the drive motor stops.

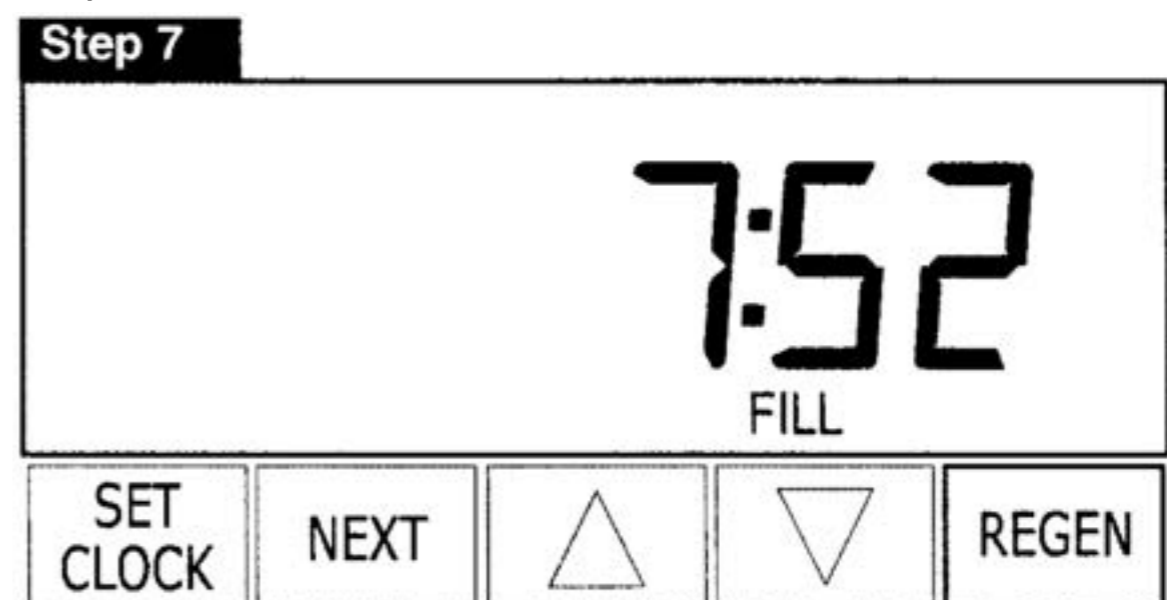

Leave the controller in this cycle for the full time allocated. The controller will advance automatically and end the cycle. Once the drive motor stops, the manual regeneration is complete and the display will return to the normal display.

Step 7: Slowly open the red outlet bypass handle by turning it counter clockwise. The handles should now be in the same position as in Figure 2 (Bypass handles may be slightly difficult to turn.) The water softener is now ready for use.

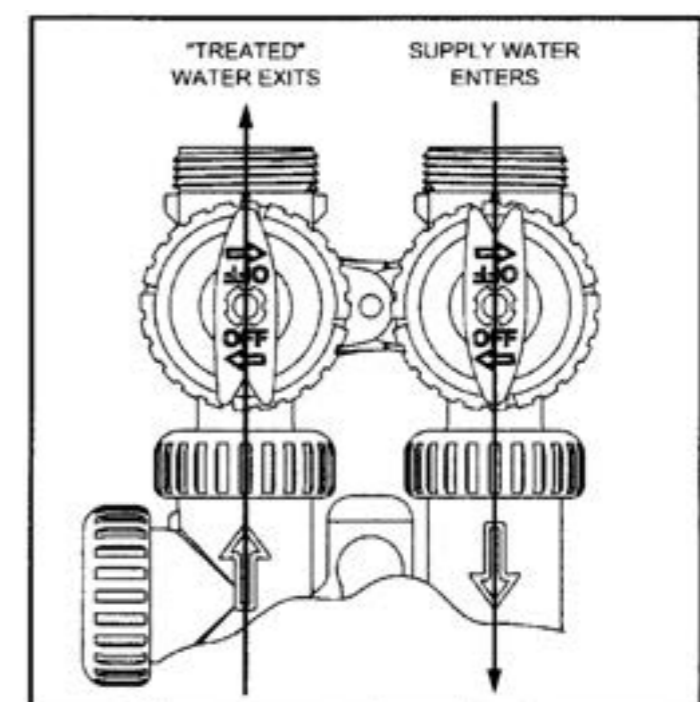
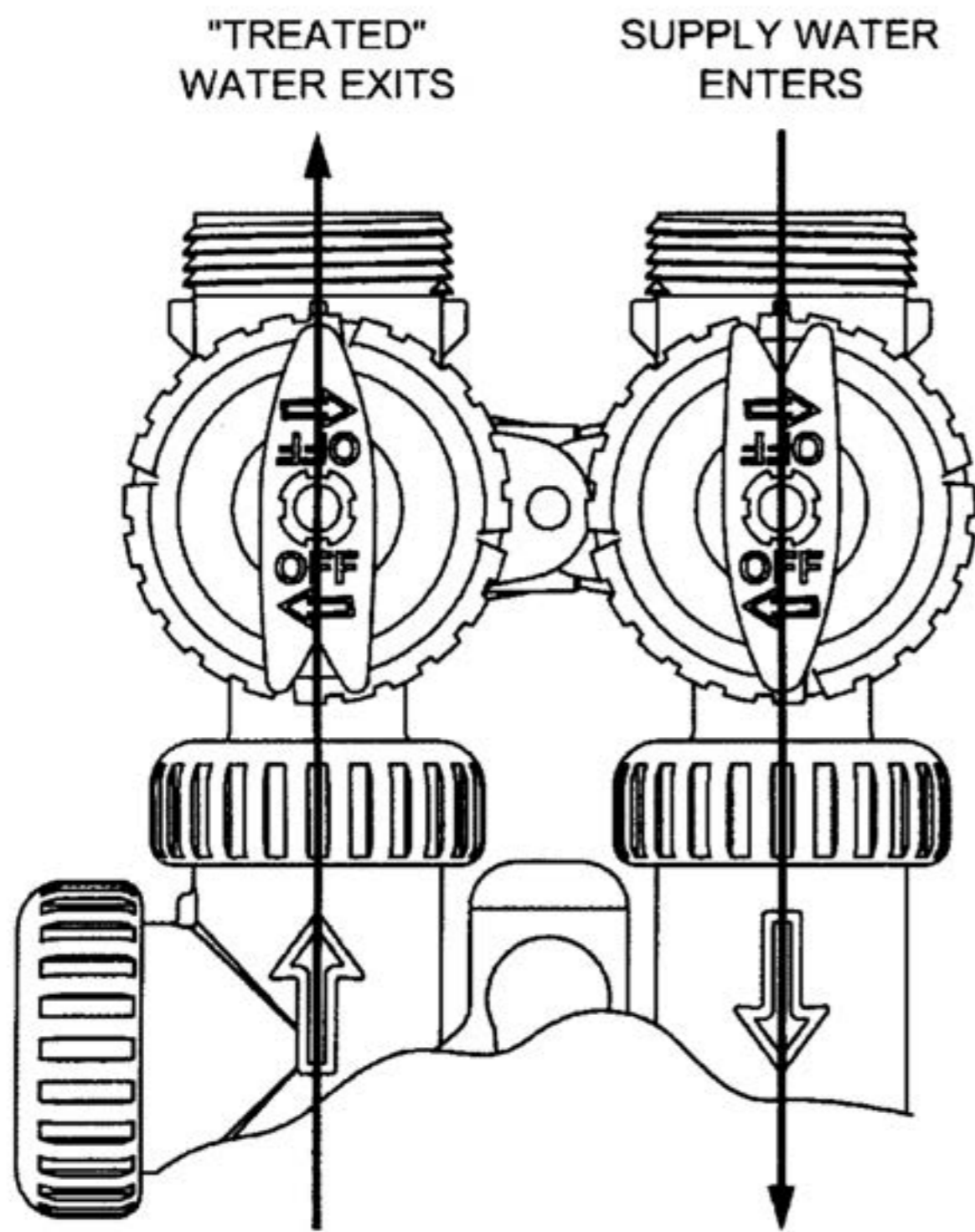

Figure 2

Bypass Valve Operation

NORMAL OPERATION



DIAGNOSTIC MODE

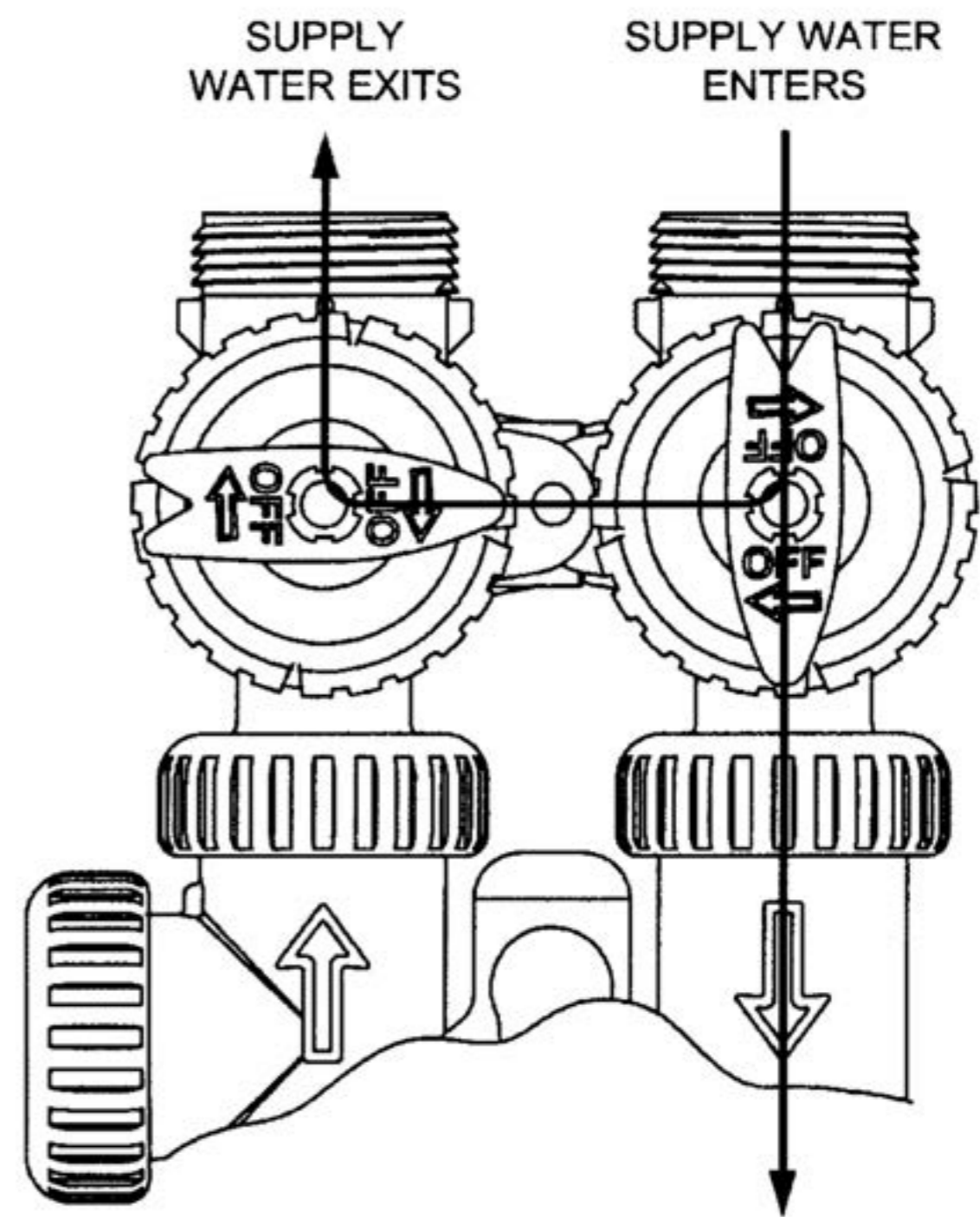

BYPASS OPERATION

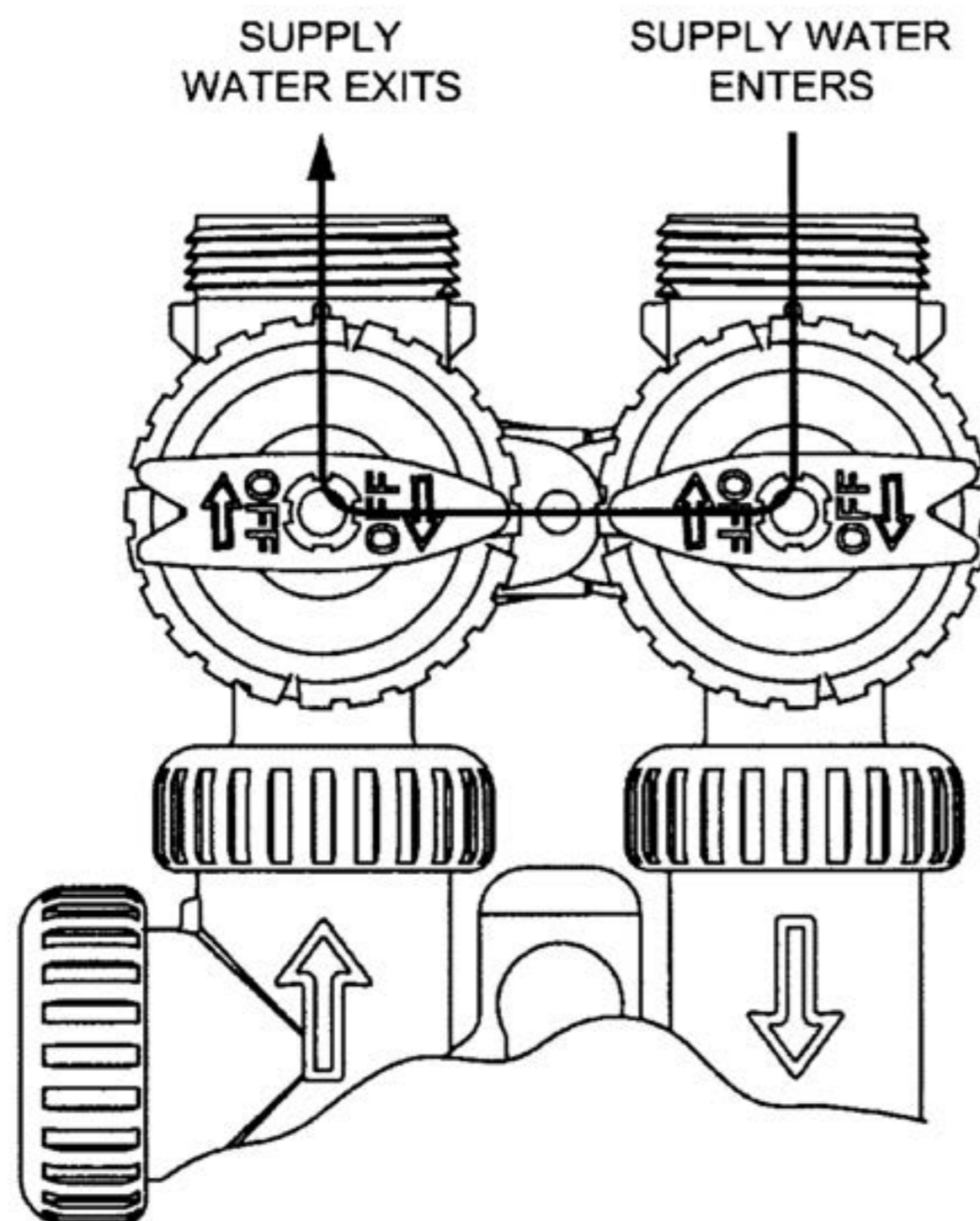

SHUT OFF MODE

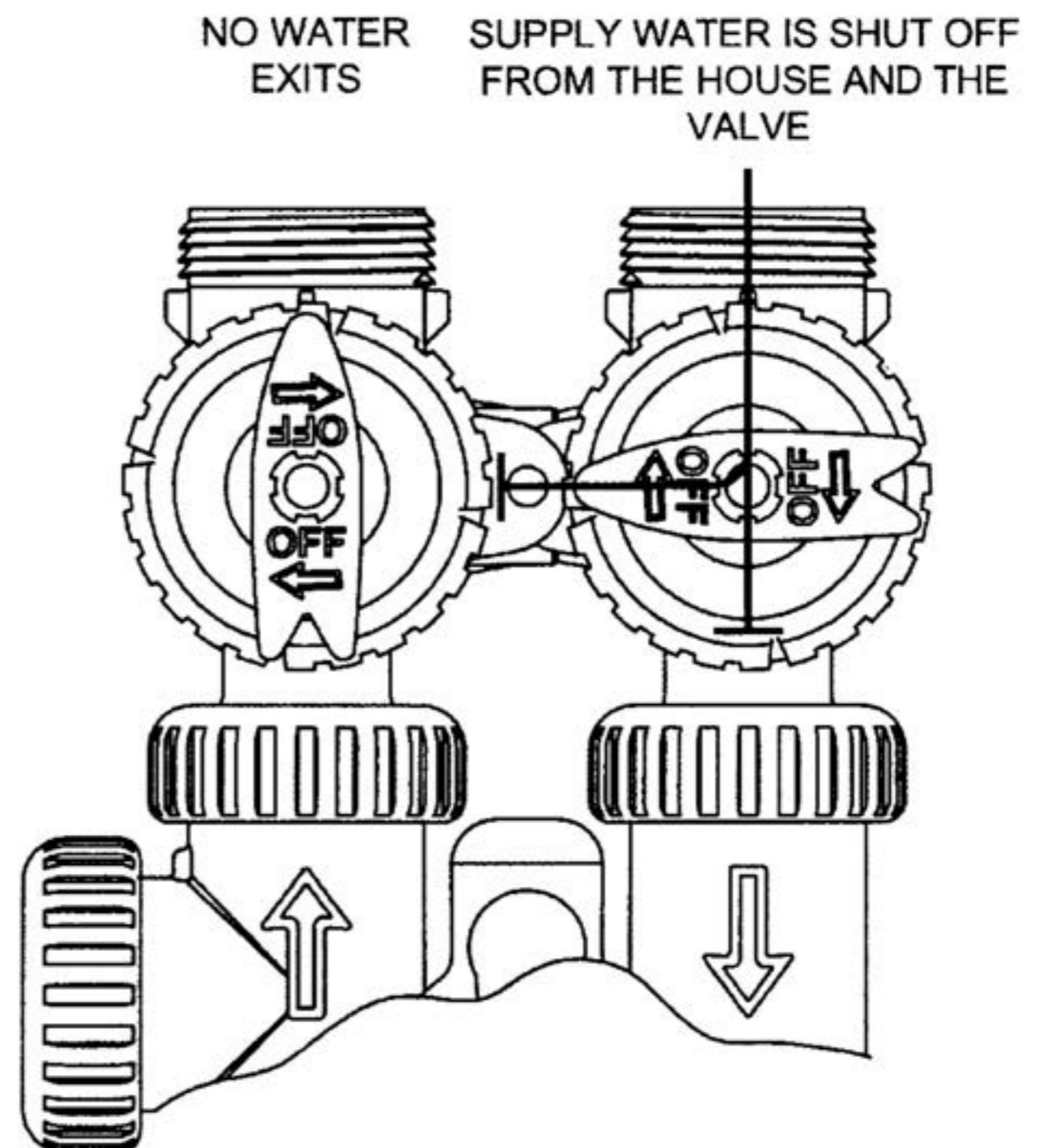

Drawings and Part Numbers

Front Cover and Drive Assembly Breakdown

Drawing No.	Order No.	Description	Quantity
1	V3175EE-01	WS1EE Front Cover Assembly	1
2	V3107-01	WS1 Motor	1
3	V3106-01	WS1 Drive Bracket & Spring Clip	1
4	V3408EE-04BO	WS1THRU/2 EE PCB 5 DIGIT REPL	1
5	V3110	WS1 Drive Gear 12x36	3
6	V3109	WS1 Drive Gear Cover	1
	V3002	WS1 Drive ASY	*
Not Shown	Not Shown	WS1 Transformer 110V-12V	1

* Drawing number parts 2 through 6 may be purchased as a complete assembly, part V3002.

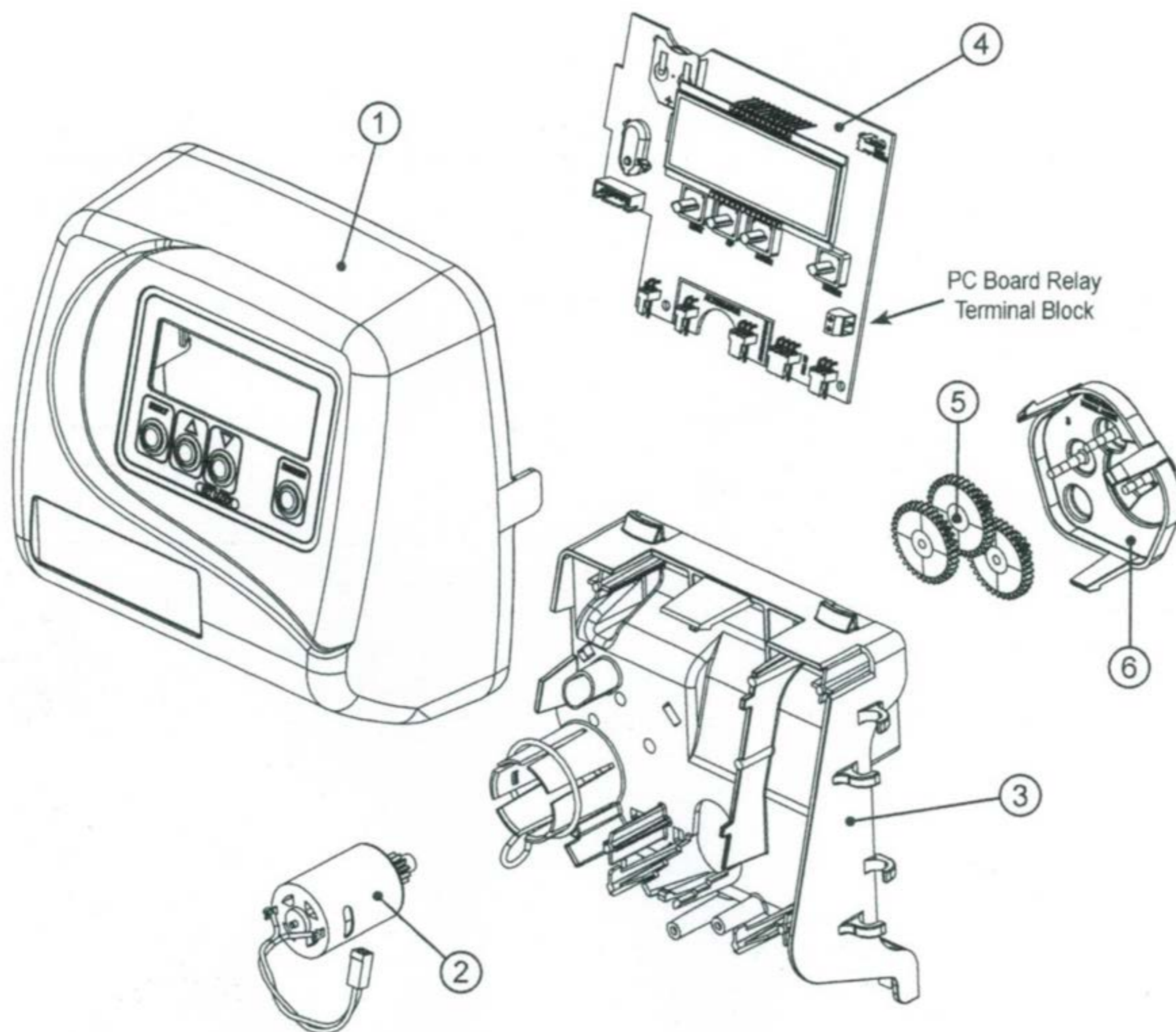

Internal Parts Breakdown

Drawing No.	Order No.	Description	Quantity
1	V3005	WS1 Spacer Stack Assembly	1
2	V3004	Drive Cap ASY	1
3	V3135	O-ring 228	1
4a	V3011*	WS1 Piston Downflow ASY	1
4b	V3011-01*	WS1 Piston Upflow ASY	1
5	V3174	WS 1 Regnerant Piston	1
6	V3180	O-ring 3371	1

***V3011 is labeled with DN and V3011-01 is labeled with UP.**

Note: The regenerant piston is not used in backwash only applications.

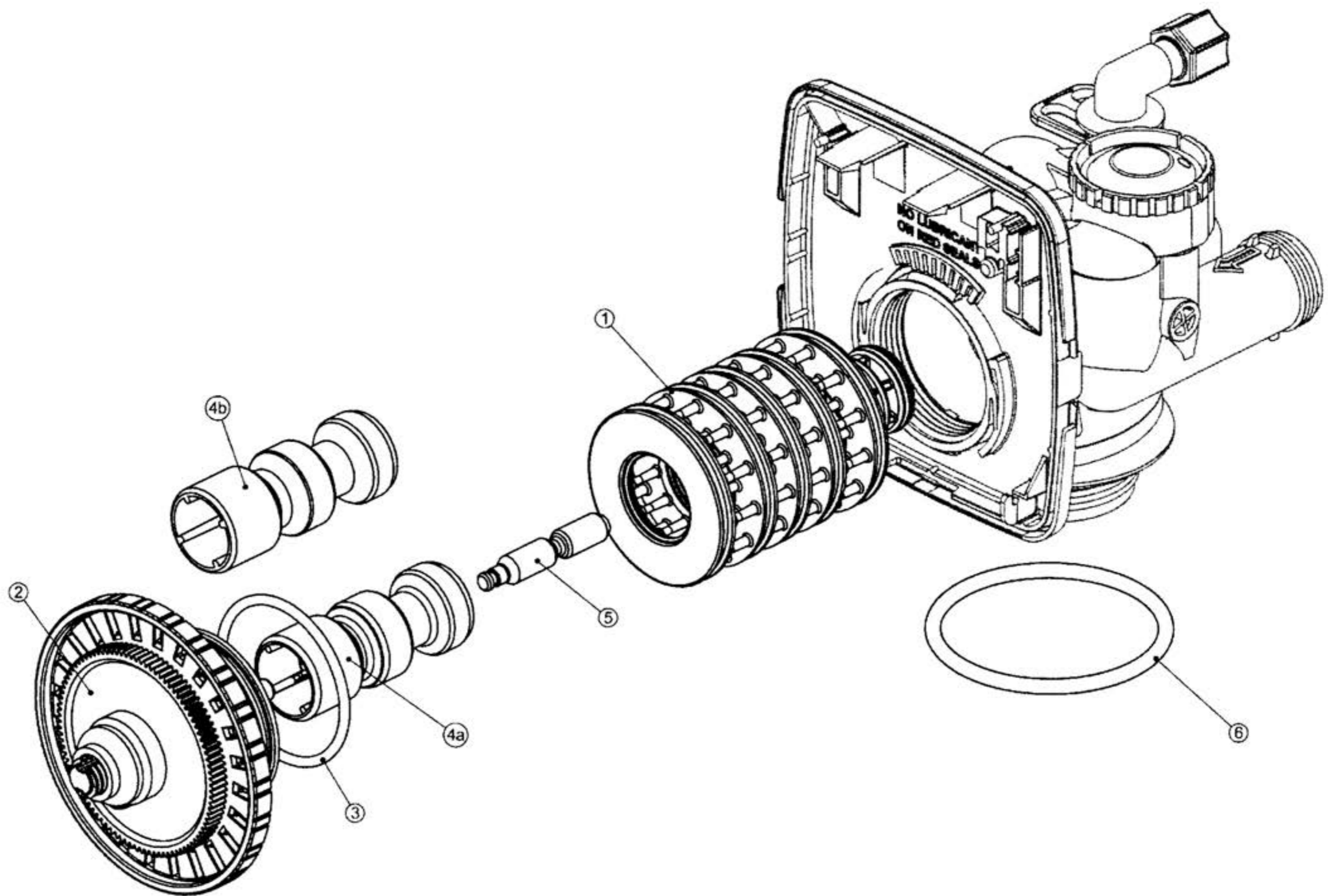

Injector Assembly Breakdown

Drawing No.	Order No.	Description	Quantity
1	V3176	Injector Ca 1	1
2	V3152	O-ring 135 1	1
3	V3177	Injector Screen 1	1
4	V3010-I1	WSI Injector ASY G Plug I	1
5	V3010-1A	WS I INJECTOR ASY A BLACK	1
	V3010-1B	WS1 INJECTOR ASY B BROWN	
	V3010-1C	WS I INJECTOR ASY C VIOLET	
	V3010-1D	WS I INJECTOR ASY D RED	
	V3010-1E	WS I INJECTOR ASY E WHITE	
	V3010-1F	WSI INJECTOR ASY F BLUE 1	
	V3010-1G	WS I INJECTOR ASY G YELLOW	
	V3010-1H	WS I INJECTOR ASY H GREEN	
	V3010-1I	WS I INJECTOR ASY I ORANGE	
	V3010-1J	WS I INJECTOR ASY J LIGHT BLUE	
V3010-1K	WS1INJECTORASYKL_IGHTGREEN		
Not Shown	V3170	O-ring 0 111	*
Not Shown	V3171	O-ring 013	*

***The injector plug and the injector each contain one 011 (lower) and 013 (upper) o-ring.**

Note: For upflow position, injector is located in the up hole and injector plug in the down hole. For a filter that only backwashes injector plugs are located in both holes

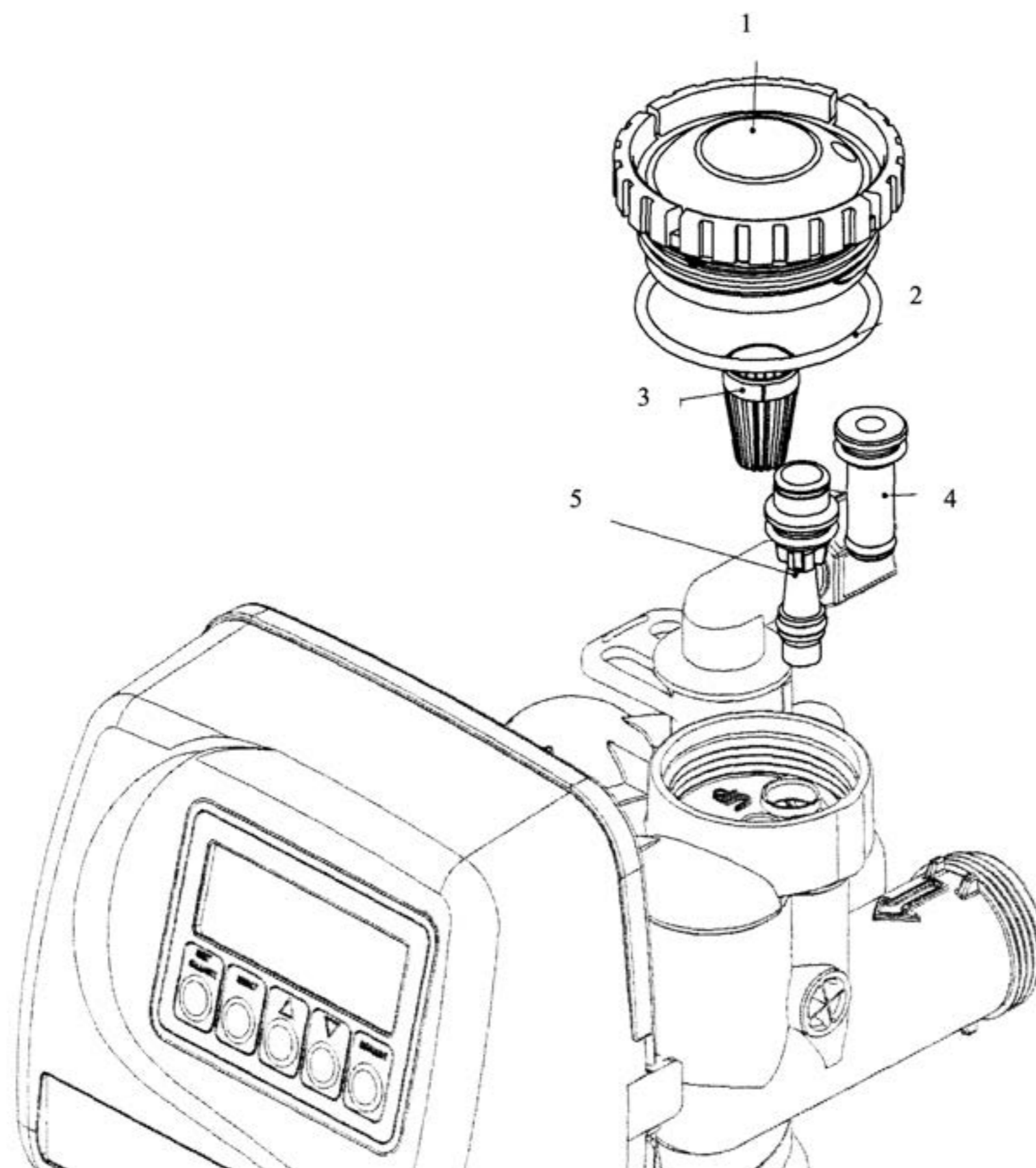

Brine Elbow Assembly Breakdown

Drawing No.	Order No.	Description	Quantity
1	V3195-01	WSI Refill Port Plug ASY	This art is required for backwash only systems
2	H4615	Elbow Lock in Clip	1
3	JCP-P-6	Pol tube insert 3/8	1
4	JCPG-6PBLK	Nut 3/8	1
5	H4613	Elbow Cap 3/8	3
6	V3163	O-ring 019	1
7	V3165-01*	WS I RFC Retainer ASY	*
8	V3182	WSI RFC	1
Not Shown	H4650	Elbow 1/2" with nut and insert	Option

*Assembly includes WS I RFC.

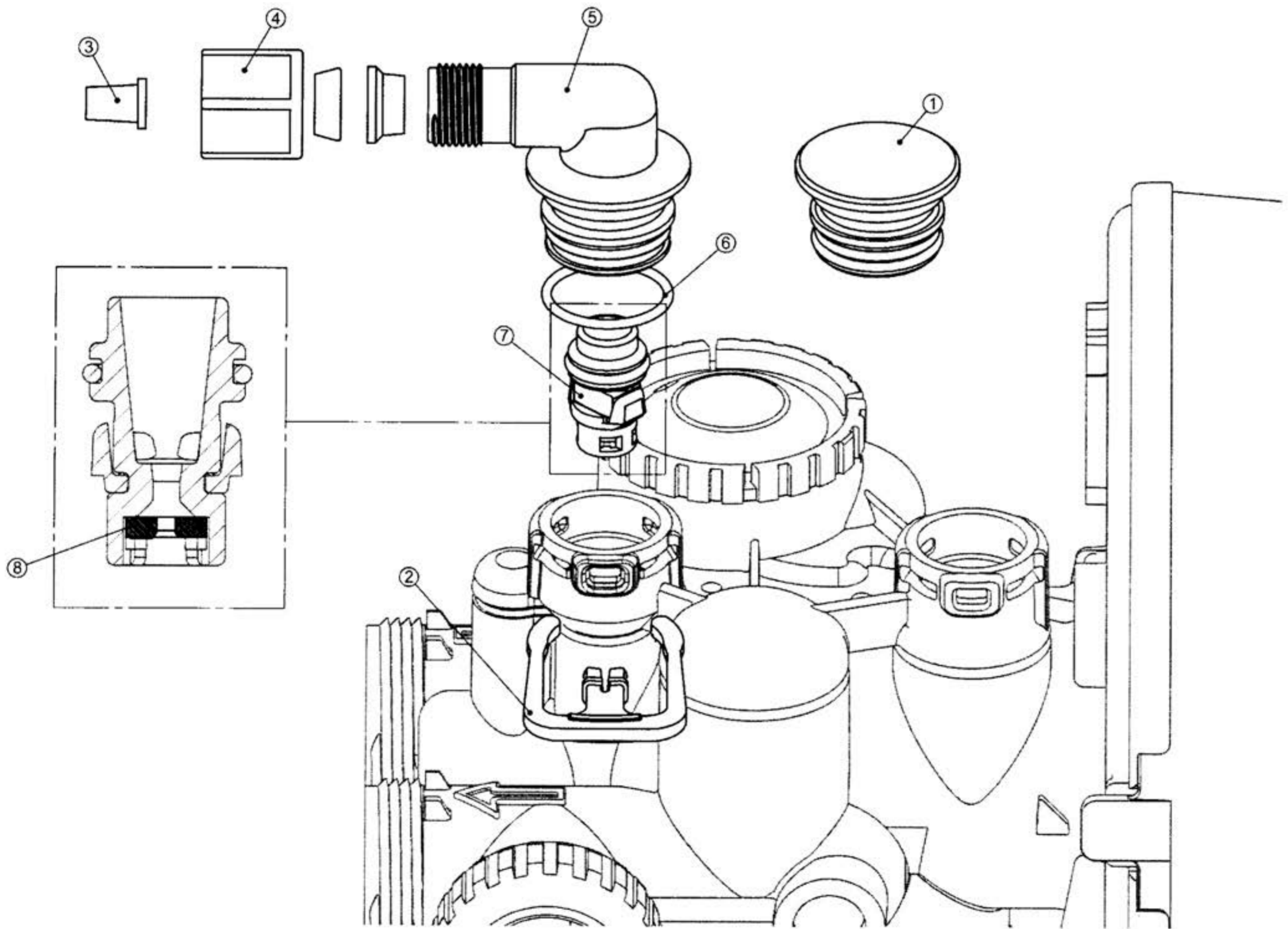

Meter Assembly Breakdown

Drawing No.	Order No.	Description	Quantity
1	V3151	WSI Nut 1" QC	1
2	V3003*	WSI Meter ASY	1
3	V3118-01	WSI Turbine ASY	1
4	V3105	O-ring 215	1
5	V3003-01	WSI Meter Plug ASY	1

*Order number V3003 includes V3118-01 and V3105.

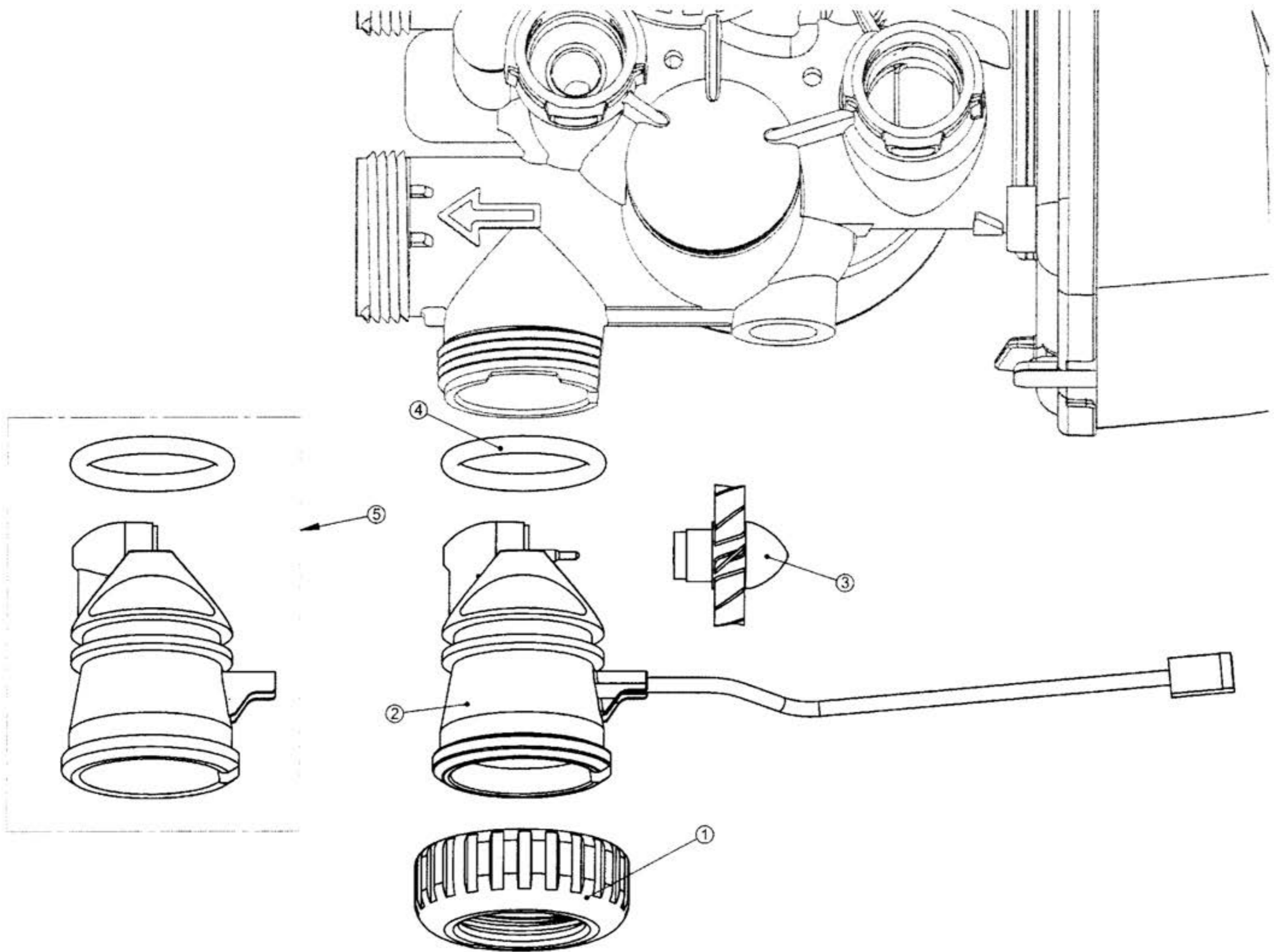

Bypass Assembly Breakdown

Drawing No.	Order No.	Description	Quantity
1	V3151	WS I Nut 1" Quick Connect	2
2	V3150	WS I Slit Ring	2
3	V3105	O-Ring 215	2
4	V3145	WS I Bypass 1" Rotor	2
5	V3146	WS I Bypass Ca	2
6	V3147	WS I Bypass Handle	2
7	V3148	WS I Bypass Rotor Seal Retainer	2
8	V3152	O-ring 135	2
9	V3155	O-ring 112	2
10	V3156	O-ring 214	2

(Not Shown) Order No. V3191-01, Description: WS I Bypass Vertical Adapter Assembly

Order No.	Description	Quantity
V3151	WS1 Nut 1" Quick Connect	2
V3150	WS1 Slit Ring	2
V3105	O-Ring 215	2
V3191-01	WSI Bypass Vertical Adapter Assembly 2	2

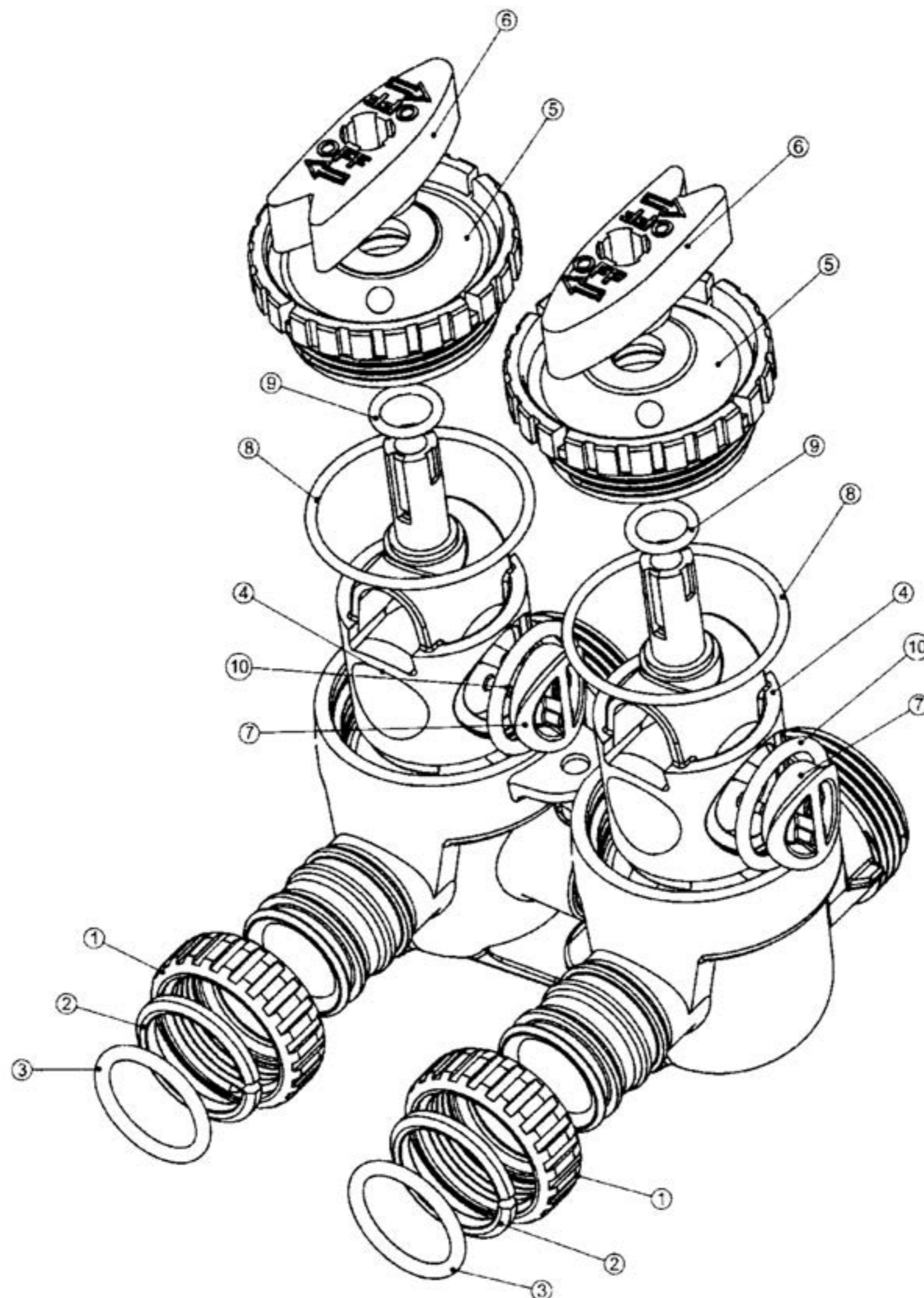

Trouble Shooting Procedures

Problem	Possible Cause	Solution
1. Timer does not display time of day	a. Transformer unplugged	a. Connect power
	b. No electric power at outlet	b. Repair outlet or use working outlet
	c. Defective transformer	c. Replace transformer
	d. Defective PC board	d. Replace PC board
2. Timer does not display correct time of day	a. Switched outlet	a. Use uninterrupted outlet
	b. Power outage	b. Reset time of day
	d. Defective PC board	d. Replace PC board
3. No softening/filtering display when water is flowing	a. Bypass valve in bypass position	a. Put bypass valve in service position
	b. Meter connection disconnected	b. Connect meter to PC board
	c. Restricted/stalled meter turbine	c. Remove meter and check for rotation or foreign material
	d. Defective meter	d. Replace meter
	e. Defective PC board	e. Replace PC board
4. Control valve regenerates at wrong time of day	a. Power outages	a. Reset control valve to correct time of day
	b. Time of day not set correctly	b. Reset to correct time of day
	c. Time of regeneration incorrect	c. Reset regeneration time
	d. Control valve set at "on 0° (immediate regeneration)	d. Check control valve set-up procedure regeneration time option
	e. Control valve set at NORMAL + on 0	e. Check control valve set-up procedure regeneration time option
5. ERROR followed by code number Error Code 1001 - Unable to recognize start of regeneration Error Code 1002 - Unexpected stall Error Code 1003 - Motor ran to long, timed out trying to reach next cycle position Error Code 1004 - Motor ran to long, timed out trying to reach home position If other Error Codes display contact the factory.	a. Control valve has just been serviced	a. Press NEXT and REGEN for 3 seconds or unplug power source jack (black wire) and plug back in to reset control valve
	b. Foreign matter is lodged in control valve	b. Check piston and spacer stack assembly for foreign matter
	c. High drive forces on piston	c. Replace piston(s) and spacer stack assembly
	d. Control valve piston not in home position	d. Press NEXT and REGEN for 3 seconds or unplug power source jack (black wire) and plug back in to reset control valve
	e. Motor not inserted fully to engage pinion, motor wires broken or disconnected, motor failure	b. Check motor and wiring. Replace motor if necessary
	f. Motor not inserted fully to engage pinion, motor wires broken or disconnected, motor failure	f. Check motor and wiring. Replace motor if necessary
	g. Drive bracket incorrectly aligned to back plate	g. Reseat drive bracket properly
	h. PC board is damaged or defective	h. Replace PC board
	i. PC board incorrectly aligned to drive bracket	i. Ensure PC board is correctly snapped on to drive bracket
6. Control valve stalled in regeneration	a. Motor not operating	a. Replace motor
	b. No electric power at outlet	b. Repair outlet or use working outlet
	c. Defective transformer	c. Replace transformer
	d. Defective PC board	d. Replace PC board
	e. Broken drive gear or drive cap assembly	e. Replace drive gear or drive cap assembly
	f. Broken piston retainer	f. Replace drive cap assembly
	g. Broken main or regenerant piston	g. Replace main or regenerant piston

Trouble Shooting Procedures

Problem	Possible Cause	Solution
7. Control valve does not regenerate automatically when REGEN button is depressed and held	a. Transformer unplugged	a. Connect power
	b. No electric power at outlet	b. Repair outlet or use working outlet
	c. Broken drive gear or drive cap assembly	c. Replace drive gear or drive cap assembly
	d. Defective PC board	d. Replace PC board
8. Control valve does not regenerate automatically but does when REGEN	a. By-pass valve in bypass position	a. Put control valve in service position
	b. Meter connection disconnected	b. Connect meter to PC board
	c. Restricted/stalled meter turbine	c. Remove meter and check for rotation or foreign matter
	d. Defective meter	d. Replace meter
	e. Defective PC board	e. Replace PC board
	f. Set-up error	f. Check control valve set-up procedure
9. Time of day flashes on and off	a. Power has been out more than two hours, the transformer was unplugged and then plugged back into the wall outlet, the transformer plug was unplugged and then plugged back into the board or the NEXT and REGEN buttons were pressed to reset the valve.	a. Reset the time of day

Manufactured with pride in Utah By:



**HOLTS WATER
CONDITIONING**

**369 South Mountainway Drive Orem, UT 84058
(801) 426-9243**

TITAN VI BLEND